

# POWERSCREEN® CRUSHING RANGE



# KNOWLEDGE IS POWER

POWERSCREEN®  
CRUSHING  
RANGE

Powerscreen means different things to different people. For some, it means robust and reliable crushing and screening equipment, designed, built and supported by passionate experts.

For others Powerscreen signifies a vast legacy of experience and knowledge used to develop a safer, more efficient working environment for all.



One of Powerscreen's most important strengths is our Global Dealer Network. 110 Companies working tirelessly worldwide to support our customers.

From your first machine purchase through to technical support, servicing and provision of spare parts, Powerscreen and our Global Dealer Network are on hand to help.

We want to be part of your legacy.  
We want you to be a part of ours.

Find your local Powerscreen dealer at  
[www.powerscreen.com](http://www.powerscreen.com)



# METROTRAK

The Powerscreen® Metrotrak is a compact, high performing mobile jaw crushing plant featuring an impressive 900mm x 600mm (35" x 23") single toggle jaw crusher. With an aggressive crushing action and a high output even at tight settings, the Metrotrak is ideally suited for operators on the mining, quarrying and recycling industries, especially those working in urban locations or where space is restricted.

The new Metrotrak builds on the legacy of the Powerscreen Metrotrak HA by improving access for chamber wedge removal, fully tunnelled product conveyor, new design bypass chute with improved internal clearances and access. Customer favourite options include a fully lowering product conveyor to aid maintenance and a hydraulically adjusted deflector plate minimising possible belt damage caused by rebar.

### Features & Benefits

- Superior tunnelling reduces the risk of rebar snagging giving excellent machine uptime
- Enhanced material flow via new design bypass chute and product conveyor
- Centralised, low-level hydraulics and electrics
- **NEW** jaw unlock option combines the benefits of hydrostatic drive with the fuel efficiency of direct drive
- Ideal for C&D waste / recycling applications with hydraulic deflector plate and hydraulically raise / lower product conveyor options
- Jaw level sensor option promotes material flow by optimising feeder speeds, increasing daily productivity
- Powerscreen Pulse intelligent monitoring as standard

### Options

- Bypass conveyor
- Single pole/twin pole magnet
- Radio remote control
- Belt weigher
- Hydraulically driven water pump
- Electric refuelling pump
- Wire mesh for underscreen
- Super tooth or multi tooth jaw plates
- Chamber unblock feature
- Hydraulic deflector plate
- Product conveyor hydraulic raise / lower
- Hydraulically folding product conveyor

### Applications

- Sand & gravel
- Blasted rock
- River rock
- C&D waste
- Overburden
- Foundry waste
- Processed ores
- Processed minerals

### METROTRAK

Weight (Est) (Tier 3) 27,920kg (61,553lbs)  
 Weight (Est) (Tier 4F) 28,000kg (61,729lbs)  
 (VGF, bypass conveyor & magnet)

Transport width 2.4m (7' 10")

Transport length 12.4m (40' 8")

Transport height 3.2m (10' 6")

Working width 3.8m (12' 6")

Working length 12.4m (40' 8")

Working height 3.2m (10' 6")



\*Depends on application  
 Engines are available that are certified to US EPA and EU off road diesel emission standards. Talk to your dealer about possible certification options (i.e. Tier 3/Stage 3A, Tier 4/Stage 3B, Tier 4F / Stage 4).

### Product Conveyor

Width: 800mm (32")  
 Discharge height: 2.9m (9'6")

### Crusher

High capacity single toggle jaw  
 Chamber size: 900mm x 600mm (35" x 23")  
 Min CSS: 40mm (1.5")\*  
 Max CSS: 100mm (4")\*

### Feeder

Vibrating pan feeder  
 Length: 3.8m (12'5")  
 Width: 800mm (2'7")

### Hopper

Wear resistant feed hopper  
 Length: 4m (13'1")  
 Width: 1.8m (5'9")  
 Capacity: 3.6m³ (4.7yds³)



### Bypass Conveyor (option)

Width: 600mm (23.6")  
 Discharge height: 2m (6'7")

### Tracks

Width: 400mm (15.7")

### Power Unit

Tier 3/Stage 3A: John Deere 4045 126kW (169hp)  
 Tier 4F/Stage 4: CAT C4.4 129kW (173hp)  
 Fuel tank capacity: 400 L (106 US GAL)



# PREMIERTRAK 300/R300

The Powerscreen® Premiertrak 300 range of high performance primary jaw crushing plants are designed for medium scale operators in quarrying, demolition, recycling & mining applications. The range includes the Premiertrak 300 with hydraulic adjust & the Premiertrak R300 with hydraulic release. User benefits include track mobility for a quick set-up time, hydraulic crusher setting adjustment for total control of product size and crusher overload protection to prevent damage by un-crushable objects.

An optional hydrostatic drive system offers versatility and allows the crusher to be operated in reverse, of particular benefit in recycling applications.

### Features & Benefits

- Ground level quick set-up with hydraulic folding feed hopper with hydraulic locking pins
- Heavy duty wear resistant feed hopper
- Stepped grizzly feeder with under-screen
- Wide bypass chute to optimise material flow
- Aggressive crushing action with high swing jaw encouraging material entry into crushing chamber
- Fully hydraulic crusher setting adjustment
- Improved manganese liner retention, protects jaw supports on both swing & fixed jaws
- Excellent under crusher access for removal of wire with hydraulic raise lower product conveyor
- Angle adjustable product conveyor, lowers for access & transport
- Low fuel consumption due to highly efficient direct drive system and low engine RPM
- Easily accessed power unit canopy
- PLC control system with auto start facility
- Remote control via umbilical
- Dust suppression system
- Fitted with Powerscreen Pulse Telematics system

### Options

- Deflector plate under crusher
- Bypass conveyor
- Single pole/twin pole magnet
- Radio remote control
- Belt weigher
- Electric refuelling pump
- Hydraulic water pump
- Urea refuelling pump
- Pre-screen system
- Stockpiler drive

### Applications

- Blasted rock
- River rock
- C & D waste
- Foundry waste
- Processed ores
- Processed minerals

### Product Conveyor

Width: 900mm (35")  
Discharge height: 3.2m (10'6")

### Crusher

High capacity single toggle jaw  
Chamber size: 1000mm x 600mm (39" x 23.6")  
Min CSS: 40mm (1.5")\*  
Max CSS: 145mm (5")\*

### Hopper

Wear resistant feed hopper  
Length: 4.3m (14' 1")  
Width: 2.05m (6' 8")  
Capacity: 5m³ (6.5yds³)

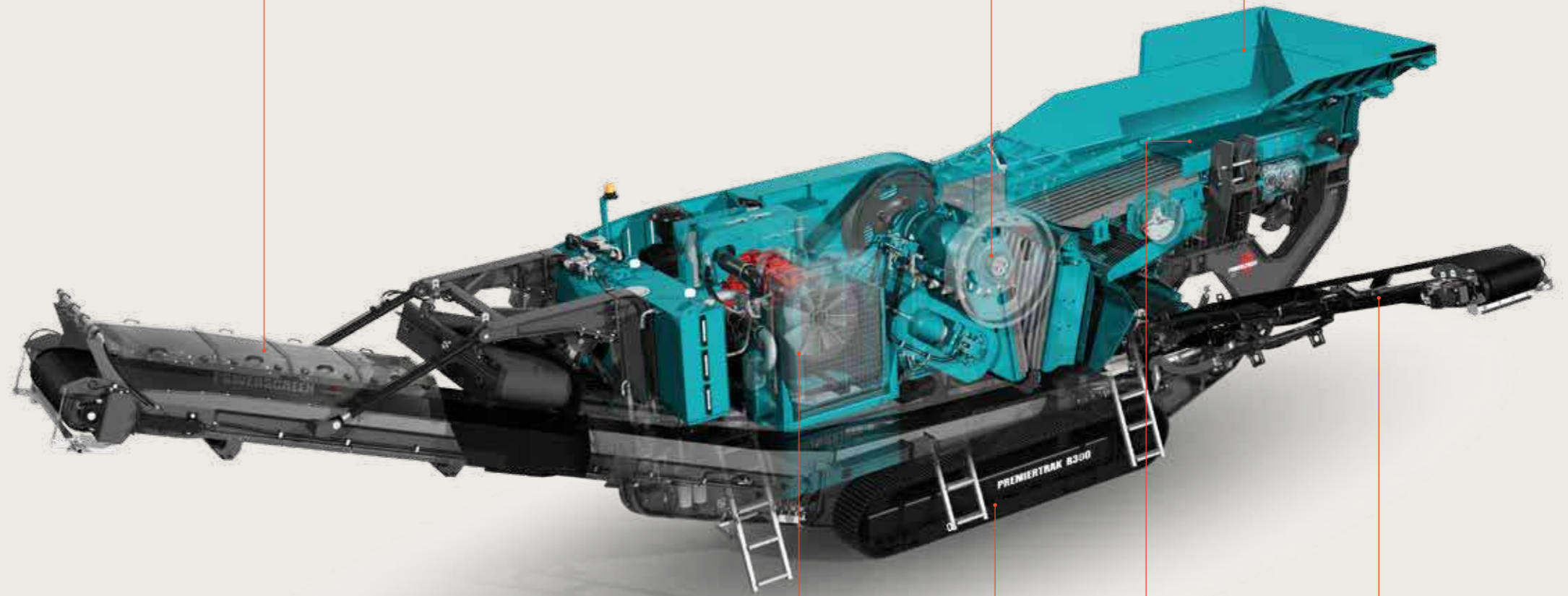

### Tracks

Width: 400mm (15.7")

### Bypass Conveyor (option)

Width: 650mm (2' 2")  
Discharge height: 2.10m (6'11")  
Discharge height: 2.75m (9')  
(extended conveyor option)

### Power Unit

Tier 3/Stage 3A:  
CAT C7.1 186kW (250hp)  
Tier 4F/Stage 4:  
CAT C7.1 205kW (280hp)  
Fuel tank capacity: 520 L (137 US Gal)

### Feeder

Vibrating pan and grizzly feeder  
Pan length: 1.73m (5' 8")  
Pan width: 0.9m (3')  
Grizzly length: 1.9m (6' 3")  
Grizzly width: 0.9m (3')

PREMIERTRAK	300	R300
Weight (est.) with side conveyor & magnet	35,000kg (77,161lbs)	36,580kg (80,645lbs)
Transport width	2.85m (8' 6")	2.55m (8' 5")
Transport length	14.1m (46' 3")	14.6m (47' 11")
Transport height	3.4m (11' 2")	3.2m (10' 6")
Working width with bypass conveyor	6.28m (20' 7")	6.28m (20' 7")
Working length	14.1m (46' 3")	14.7 (48' 3")
Working height	3.4m (11' 2")	3.85m (12' 8")



\*Depends on application  
Engines are available that are certified to US EPA and EU off road diesel emission standards. Talk to your dealer about possible certification options (i.e. Tier 3/Stage 3A, Tier 4/Stage 3B, Tier 4F / Stage 4).



# PREMIERTRAK 400X/R400X

The Powerscreen® Premiertrak 400X range of high performance primary jaw crushing plants are designed for medium scale operators in quarrying, demolition, recycling and mining applications. The range includes the Premiertrak 400X with hydraulic adjust and the Premiertrak R400X with hydraulic release. User benefits include track mobility for a quick set-up time (typically under 30 minutes,) hydraulic crusher setting adjustment for total control of product size and crusher overload protection to prevent damage by uncrushable objects.

### Features & Benefits

- High output and excellent reduction capability
- Wear resistant hydraulic folding feed hopper with hydraulic wedge fixing system
- Excellent under crusher access for removal of wire with hydraulic raise lower product conveyor
- Stepped self-cleaning grizzly feeder with under feeder screen option
- Deep fines chute to reduce material blockages
- Improved bypass chute to increase material flow
- Aggressive crushing action with high swing jaw encouraging material entry into crushing chamber
- Hydraulic crusher setting adjustment
- Improved manganese liner retention, protects jaw supports on both swing & fixed jaws
- Economical to operate with low fuel consumption due to highly efficient direct drive system
- Angle adjustable product conveyor
- Easy access power unit canopy
- PLC control system with auto start facility
- Remote control via umbilical
- Dust suppression system
- Easily set up
- Fitted with Powerscreen Pulse Telematics system
- 650mm wide bypass conveyor
- Fully inclined catwalks

### Options

- Patented hydraulic deflector plate under crusher
- Bypass conveyor /extended bypass conveyor
- Single pole/twin pole magnet
- Radio remote control
- Belt weigher
- Electric refuelling pump
- Hydraulically driven water pump
- Wire mesh for underscreen
- Super tooth or multi tooth jaw plates
- Extended hopper
- Postscreen available (will add est 6 tonnes to a machine weight)
- Unblock motor
- Extended main conveyor
- Over crusher level sensor
- Patented hydraulic crusher overload system, ideal for applications with un-crushable material in feed, 200mm<sup>2</sup>.
- Pre-screen available

### Applications

- Sand & gravel
- Blasted rock
- River rock
- C & D waste
- Overburden
- Foundry waste
- Processed ores
- Processed minerals

### Product Conveyor

Width: 1000mm (39")  
Discharge height: 3.5m (11'5")

### Crusher

High capacity single toggle jaw  
Chamber size: 1100mm x 700mm (44" x 28")  
Min CSS: 50mm (2")\*  
Max CSS: 150mm (6")\*

### Hopper

Wear resistant feed hopper  
Length: 4.9m (16' 1")  
Width: 2.49m (8'2")  
Capacity: 10m<sup>3</sup> (13yds<sup>3</sup>)

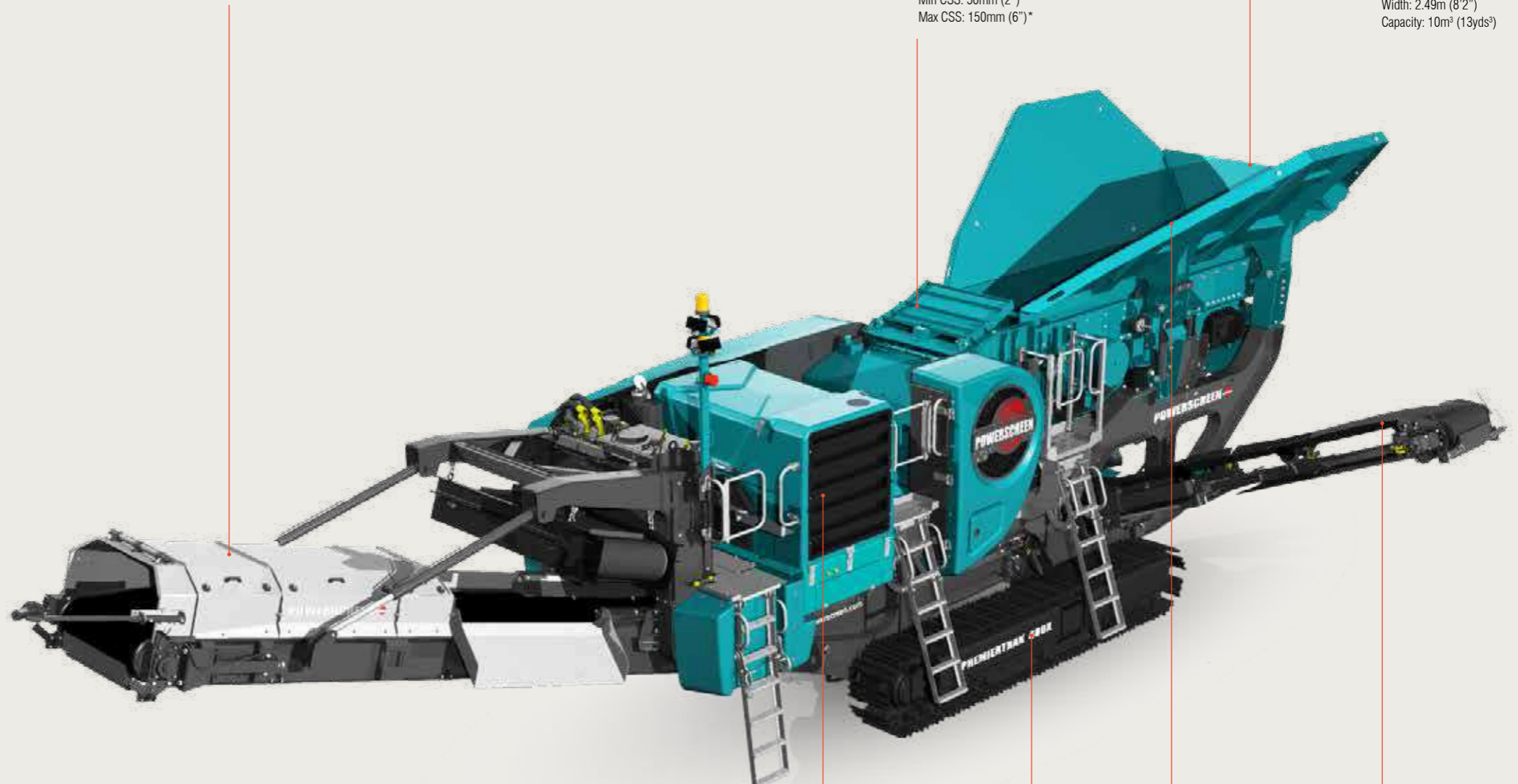

### Power Unit

Tier 3/Stage 3A:  
CAT C9 ACERT 194kW (260hp)  
Tier 4F/Stage 4:  
Scania DC9 84A 202kW (275hp)  
Fuel tank capacity: 450 L (119 US Gal)  
Constant speed option

### Tracks

Width: 500mm (19.7")

### Feeder

Vibrating pan and grizzly feeder  
Feeder length: 4.20m (13'9")  
Feeder width: 1.06m (3' 6")  
Grizzly length: 2.12m (7")

### Bypass Conveyor (option)

Width: 650mm (25.6")  
Discharge height: 2.2m (7'2")

### PREMIERTRAK 400X/R400X

Weight (Est) (Tier 3)	46,300kg (102,274lbs)
Weight (Est) (Tier 4F)	46,500kg (102,514lbs)
Transport width	2.8m (9'2")
Transport length	15.02m (49'3")
Transport height	3.4m (11'2")
Working width with Bypass conveyor	4.33m (14'2")
Working length	14.66m (48'1")
Working height	4.13m (13'6")



\*Depends on application  
Engines are available that are certified to US EPA and EU off road diesel emission standards. Talk to your dealer about possible certification options (i.e. Tier 3/Stage 3A, Tier 4F / Stage 4, Constant speed).

# PREMIERTRAK 400X/R400X POST-SCREEN

The Powerscreen® Premiertrak 400X range of high performance primary jaw crushing plants are designed for medium scale operators in quarrying, demolition, recycling and mining applications. The range includes the Premiertrak 400X with hydraulic adjust and the Premiertrak R400X with hydraulic release. The Premiertrak 400X post-screen allows users to generate a type one product at high volume from one machine. It has been designed so that it has a quick release system, to ensure maximum uptime and easy service and maintenance.

### Features & Benefits

- High output and excellent reduction capability
- Wear resistant hydraulic folding feed hopper with hydraulic wedge fixing system
- Excellent under crusher access for removal of wire with hydraulic raise lower product conveyor
- Stepped self-cleaning grizzly feeder with under feeder screen option
- Deep fines chute to reduce material blockages
- Improved bypass chute to increase material flow
- Aggressive crushing action with high swing jaw encouraging material entry into crushing chamber
- Hydraulic crusher setting adjustment
- Improved manganese liner retention, protects jaw supports on both swing & fixed jaws
- Economical to operate with low fuel consumption due to highly efficient direct drive system
- Angle adjustable product conveyor
- Easy access power unit canopy
- PLC control system with auto start facility
- Remote control via umbilical
- Dust suppression system
- Easily set up
- Fitted with Powerscreen Pulse Telematics system
- 650mm wide bypass conveyor
- Fully inclined catwalks
- Single deck post-screen

### Options

- Patented hydraulic deflector plate under crusher
- Bypass conveyor /extended bypass conveyor
- Single pole/twin pole magnet
- Radio remote control
- Belt weigher
- Electric refuelling pump
- Hydraulically driven water pump
- Wire mesh for underscreen
- Super tooth or multi tooth jaw plates
- Extended hopper
- Unblock motor
- Extended main conveyor
- Over crusher level sensor
- Patented hydraulic crusher overload system, ideal for applications with un-crushable material in feed, 200mm<sup>2</sup>
- Pre-screen

### Applications

- Sand & gravel
- Blasted rock
- River rock
- C & D waste
- Overburden
- Foundry waste
- Processed ores
- Processed minerals

### PREMIERTRAK 400/400X Post-Screen

Weight (Est) (Tier 3)	52,300kg (115,301lbs)
Weight (Est) (Tier 4F)	52,500kg (115,742lbs)
Transport width	2.8m (9'2")
Transport length	15.52m (50'11")
Transport height	3.4m (11'2")
Working width with bypass conveyor	4.33m (14'2")
Working length	16.64m (54'7")
Working height	4.13m (13'6")



### Product Conveyor

Width: 1000mm (39")  
Discharge height: 3.5m (11'5")

### Crusher

High capacity single toggle jaw  
Chamber size: 1100mm x 700mm (44" x 28")  
Min CSS: 50mm (2")\*  
Max CSS: 150mm (6")\*

### Hopper

Wear resistant feed hopper  
Length: 4.9m (16' 1")  
Width: 2.49m (8'2")  
Capacity: 10m<sup>3</sup> (13yds<sup>3</sup>)

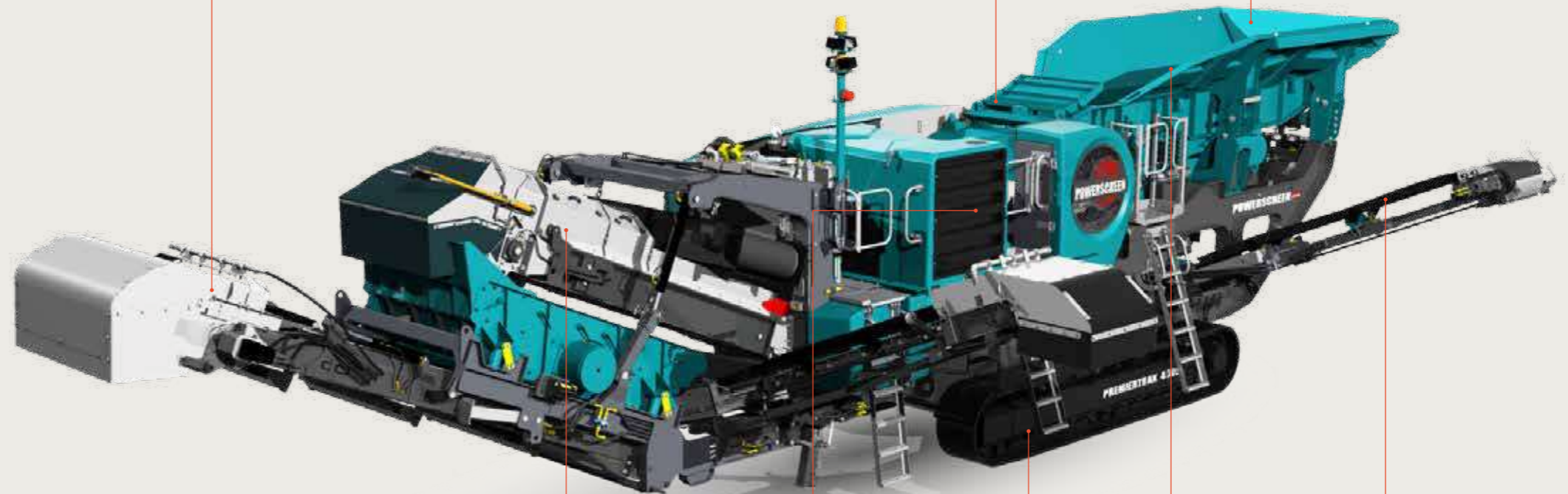

### Single deck post-screen

Screen area: 2.44m x 1.52m (8' x 5')  
Discharge height: 2.8m (9' 2")

### Power Unit

Tier 3/Stage 3A:  
CAT C9 ACERT 194kW (260hp)  
Tier 4F/Stage 4:  
Scania DC9 84A 202kW (275hp)  
Fuel tank capacity: 450 L (119 US Gal)  
Constant speed option

### Tracks

Width: 500mm (19.7")

### Feeder

Vibrating pan and grizzly feeder  
Feeder length: 4.20m (13'9")  
Feeder width: 1.06m (3' 6")  
Grizzly length: 2.12m (7")

### Bypass Conveyor (option)

Width: 650mm (25.6")  
Discharge height: 2.2m (7'2")

\*Depends on application

Engines are available that are certified to US EPA and EU off road diesel emission standards. Talk to your dealer about possible certification options (i.e. Tier 3/Stage 3A, Tier 4F / Stage 4, Constant speed).

# PREMIERTRAK 600/600E

The Powerscreen® Premiertrak 600 range of high performance primary jaw crushing plants are designed for large and medium scale operators in quarrying, demolition, recycling & mining applications. The range includes the Premiertrak 600 & Premiertrak 600E both equipped with the advanced high performance 1200mm x 820mm Terex chamber. Built for the toughest of applications, the robust construction and modern design of the Premiertrak 600 ensures optimum performance, reliability and efficiency.

The Premiertrak 600E comes complete with an on-board diesel generator. The machine can be powered from this, or from an external power supply. There is sufficient excess power available to run a second machine such as a screener. This versatility along with the electrically driven crusher and conveyors makes the Premiertrak 600E highly efficient, economical and environmentally friendly.

### Features & Benefits

- Ground level quick set-up with hydraulic folding feed hopper with hydraulic locking system
- Heavy duty wear resistant feed hopper
- Stepped self-cleaning grizzly feeder with under feeder screen
- Wide bypass chute to optimise material flow
- Aggressive crushing action with high swing jaw encouraging material entry into crushing chamber
- Fully hydraulic crusher setting adjustment
- Excellent under crusher access for removal of wire with hydraulic raise lower product conveyor
- Angle adjustable product conveyor, lowers for access & transport
- Low fuel consumption due to highly efficient direct drive system and low engine RPM
- Easily accessed power-unit canopy
- Modern & user-friendly PLC control system with auto start facility
- Remote control via umbilical
- Dust suppression system
- Fitted with Powerscreen Pulse Telematics system

### Options

- Pre-screen system
- Wire mesh for underscreen (standard)
- Quarry tooth, pyramid tooth or heavy duty fixed jaw plates
- Deflector plate under crusher
- Bypass conveyor
- Single pole overband magnetic separator
- Twin pole overband magnetic separator
- Belt weigher
- Electric refuelling pump
- Electric urea pump
- Hydraulic water pump
- Radio remote control
- Stockpiler drive (Tier 4 machines only)

### Applications

- Sand & gravel
- Blasted rock
- River rock
- C & D waste
- Overburden
- Foundry waste
- Processed ores
- Processed minerals

PREMIERTRAK	600	600E
Weight (est.) with bypass conveyor & magnet	68,875kg (151,843lbs)	72,725kg (162,535lbs)
Transport width	3m (9' 10")	3.12m (10' 3")
Transport length	17.1m (56' 1")	17.1m (56' 1")
Transport height	3.8m (12' 5")	3.8m (12' 5")
Working width with bypass conveyor	8.09m (26' 5")	8.09m (26' 7")
Working length	16.63m (54' 7")	16.63m (54' 7")
Working height	4.49m (14' 9")	4.49m (14' 9")



\*Depends on application  
Engines are available that are certified to US EPA and EU off road diesel emission standards. Talk to your dealer about possible certification options (i.e. Tier 3/Stage 3A, Tier 4/Stage 3B, Tier 4F / Stage 4).

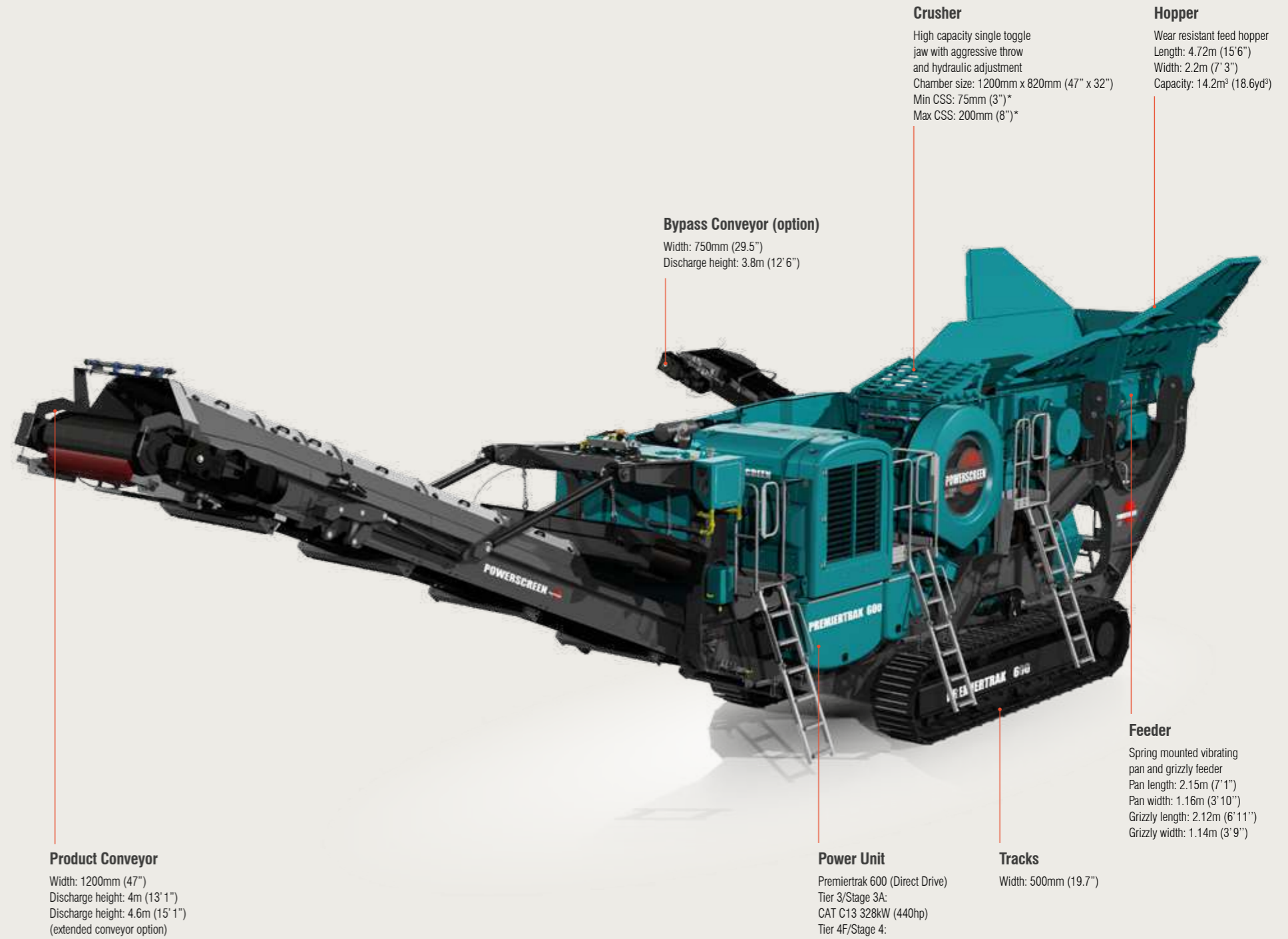

# 1000 MAXTRAK

The high performance Powerscreen® 1000 Maxtrak is a small to medium sized cone crusher which has been designed for direct feed applications without pre-screening on clean rock. At its heart is the Automax® cone crusher which provides excellent reduction and product cubicity for the production of high quality aggregate and sub-base material. Hydraulic release capabilities are designed so that any uncrushable material entering the chamber is safely discharged.

**Features & Benefits**

- Renowned Automax® crusher technology
- Accepts clean all in feed
- Excellent product shape
- High reduction ratio
- Cone feed box level control to maintain choke feeding
- Hydraulic crusher setting
- Cone overload protection
- Heavy duty chassis and track frame
- Metal detector
- Dust suppression system
- Economical to operate with a highly fuel efficient direct drive system
- Fitted with Powerscreen Pulse Telematics system

**Options**

- Concaves: extra coarse, medium coarse, coarse, Autosand®
- Short throw eccentric
- Feed hopper extension plates
- Product conveyor belt weigher
- Electric refuelling pump
- Hydraulic water pump
- Radio remote control
- Urea refuelling pump

**Applications**

- Sand & gravel
- Blasted rock
- River rock
- C & D waste
- Foundry waste
- Processed ores
- Processed minerals

**Product Conveyor**

Width: 800mm (32")  
Discharge height: 3.25m (10' 8")

**Crusher**

Automax® cone crusher with all roller bearing design  
Size (head diameter): 1000mm (39")  
Concave standard: Medium coarse  
Min CSS: 18mm (0.7")\*  
Max CSS: 36mm (1.4")\*

**Feed Conveyor**

Width: 1000mm (39")  
Over and under belt metal detector

**Hopper**

Wear resistant feed hopper  
Length: 3.38m (11')  
Width: 2.5m (8'2")  
Capacity: 4.4m³ (5.8yds³)



**1000 MAXTRAK**

Weight (Est)	30,440kg (67,108lbs)
Transport width	2.8m (9'2")
Transport length	14.6m (47'11")
Transport height	3.46m (11'4")
Working width	2.8m (9'2")
Working length	14.6m (47'11")
Working height	4.1m (13'5")



**Power Unit**

Tier 3/Stage 3A:  
CAT C9 ACERT 242kW (325hp)  
Fuel tank capacity: 552 L (137 US Gal)  
Tier 4F/Stage 4:  
Scania DC09 257kW (350hp)  
Fuel tank capacity: 650 L (171 US Gal)

**Tracks**

Width: 400mm (15.7")

\*Depends on application  
Engines are available that are certified to US EPA and EU off road diesel emission standards. Talk to your dealer about possible certification options (i.e. Tier 3/Stage 3A, Tier 4/Stage 3B, Tier 4F / Stage 4).





# 1000SR

The Powerscreen® 1000SR is built around the successful 1000 Maxtrak model and features a re-circulating conveyor and a double-deck post-screen to provide a complete crushing and screening process on a single chassis. The machine is designed for direct feed applications without pre-screening on clean rock. At its heart is the Automax® cone crusher which provides excellent reduction and product cubicity for the production of high quality aggregate and sub-base material. Hydraulic release capabilities are designed so that any uncrushable material entering the chamber is safely discharged. Suitable for secondary and tertiary applications, the 1000SR can produce up to three products when oversized material doesn't require re-circulation to the crusher.

**Features & Benefits**

- Renowned Automax® crusher technology
- Accepts clean all in feed
- Excellent product shape
- High reduction ratio
- Cone feed box level control to maintain choke feeding
- Hydraulic crusher setting
- Cone overload protection
- Heavy duty chassis and track frame
- Metal detector
- Dust suppression system
- Economical to operate with a highly fuel efficient direct drive system
- Patented double deck post screen.
- Suitable for re-circulating oversized material
- Fitted with Powerscreen Pulse Telematics system

**Options**

- Concaves: extra coarse, medium coarse, coarse, Autosand®
- Short throw eccentric
- Feed hopper extension plates
- Product conveyor belt weigher
- Electric refuelling pump
- Hydraulic water pump
- Radio remote control
- Urea refuelling pump
- Additional stockpiling conveyor for mid-grade product

**Applications**

- Sand & gravel
- Blasted rock
- River rock
- C & D waste
- Foundry waste
- Processed ores
- Processed minerals

**1000SR**

Weight (Est)	39,640kg (87,391lbs)
Transport width	3.1m (10'2")
Transport length	16.9m (55'5")
Transport height	3.45m (11'4")
Working width	3.1m (10'2")
Working length	16.9m (55'5")
Working height	4.85m (15'11")



\*Depends on application  
Engines are available that are certified to US EPA and EU off road diesel emission standards. Talk to your dealer about possible certification options (i.e. Tier 3/Stage 3A, Tier 4/Stage 3B, Tier 4F / Stage 4).

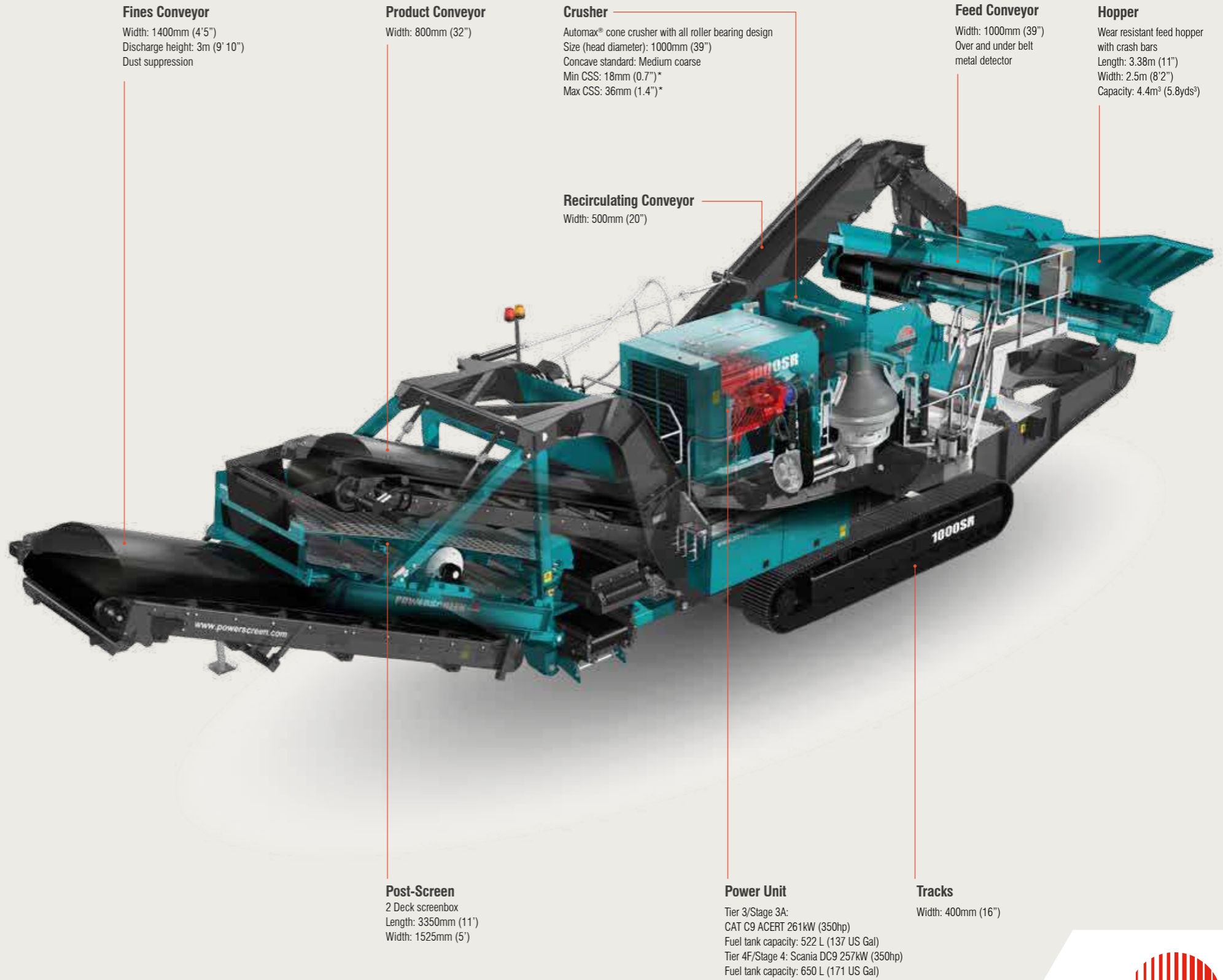

# 1150 MAXTRAK

The high performance Powerscreen® 1150 Maxtrak is a medium sized cone crusher which has been designed for direct feed applications without pre-screening on clean rock. At its heart is the Automax® cone crusher which provides excellent reduction and product cubicity for the production of high quality aggregate and sub-base material. Hydraulic release capabilities are designed so that any uncrushable material entering the chamber is safely discharged.

**Features & Benefits**

- Renowned Automax® crusher technology
- Accepts clean all in feed
- Excellent product shape
- High reduction ratio
- Cone feed box level control to maintain choke feeding
- Hydraulic crusher setting
- Cone overload protection
- Heavy duty chassis and track frame
- Metal detector
- Dust suppression system
- Direct drive – Increased fuel efficiency and reduced operating costs
- Fitted with Powerscreen Pulse Telematics system

**Options**

- Concaves: extra coarse, medium coarse, fine
- Short throw eccentric
- Camera over crusher
- Feed hopper extension plates
- Product conveyor dust covers
- Product conveyor stockpile sensor
- Product conveyor belt weigher
- Cold climate oils
- Hot climate oils
- Hot climate coolers
- Urea re-fuelling pump
- Diesel re-fuelling
- Hydraulic water pump
- Radio remote control
- Lighting mast
- Control panel positive air pressurization

**Applications**

- Sand & gravel
- Blasted rock
- River rock
- C & D waste
- Foundry waste
- Processed ores
- Processed minerals

**Product Conveyor**

Width: 1000mm (39")  
Discharge height: 3.30m (10'10")

**Crusher**

Automax® cone crusher with all roller bearing design  
Size (head diameter): 1150mm (45")  
Concave standard: Medium coarse  
Min CSS: 18mm (0.7")\*  
Max feed size: 180mm (7.1")\*

**Hopper**

Wear resistant feed hopper with crash bars  
Length: 3.5m (11'6")  
Width: 2.25m (7'5")  
Capacity: 6m³ (7.8yds³)



**1150 MAXTRAK**

Weight (Est)	42,900kg (94,578lbs) (no options)
Transport width	3m (9'10")
Transport length	16.9m (55'5")
Transport height	3.6m (11'10")
Working width	4.5m (14'9")
Working length	16.4m (53'10")
Working height	5.6m (18'4")



\*Depends on application  
Engines are available that are certified to US EPA and EU off road diesel emission standards. Talk to your dealer about possible certification options (i.e. Tier 3/Stage 3A, Tier 4/Stage 3B, Tier 4F / Stage 4).

**Power Unit**

Tier 3/Stage 3A:  
CAT C13 ACERT 328kW (440hp)  
Tier 4F/Stage 4:  
Scania DC13 331kW (450hp)  
Fuel tank capacity: 1000 L (264 US gal)

**Feed Conveyor**

Width: 1200mm (47")  
Over and under belt metal detector

**Tracks**

Width: 500mm (20")



# 1150 MAXTRAK PRE-SCREEN

The Powerscreen® 1150 Maxtrak Pre-Screen is a high performance, medium sized track mobile cone crusher with an independent pre-screening system. At the heart of the Maxtrak is the Automax® cone crusher with hydraulic setting, tramp release & unblocking system. Its unique crushing action provides excellent capacity, high reduction & good product cubicity for the production of high quality aggregate & sub-base materials. The added pre-screen option allows a sized product or dirt to be removed from the feed prior to entering the cone, thus maximising output capacity and quality. The 1150 Maxtrak Pre-Screen features a patent pending hydraulic folding system which allows for rapid conversion between pre-screen and direct feed configurations providing unrivalled versatility. A level probe over the feed ring regulates the feed belt to ensure the cone chamber is choke fed, essential for maximum reduction, manganese life & optimal product shape.

**Features & Benefits**

- Renowned Automax® crusher technology
- Accepts clean all in feed
- Excellent product shape
- High reduction ratio
- Cone feed box level control to maintain choke feeding
- Hydraulic crusher setting
- Cone overload protection
- Heavy duty chassis and track frame
- Metal detector
- Dust suppression system
- Direct drive – Increased fuel efficiency and reduced operating costs
- Patent pending hydraulic folding system provides rapid conversion between pre-screen and direct feed configurations
- Fitted with Powerscreen Pulse Telematics system

**Options**

- Concaves: extra coarse, medium coarse, fine
- Short throw eccentric
- Camera over crusher
- Feed hopper extension plates
- Product conveyor dust covers
- Product conveyor stockpile sensor
- Product conveyor belt weigher
- Cold climate oils
- Hot climate oils
- Hot climate coolers
- Urea re-fuelling pump
- Diesel re-fuelling
- Hydraulic water pump
- Radio remote control
- Lighting mast
- Control panel positive air pressurization

**Applications**

- Sand & gravel
- Blasted rock
- River rock
- C & D waste
- Foundry waste
- Processed ores
- Processed minerals

**1150 MAXTRAK PRE-SCREEN**

Weight (Est)	51,020kg (112,479lbs)
Transport width	3m (9'10")
Transport length	17.7m (58'1")
Transport height	3.8m (12'6")
Working width	6.45m (21'2")
Working length	19.10m (62'8")
Working height	5.6m (18'4")



\*Depends on application  
Engines are available that are certified to US EPA and EU off road diesel emission standards. Talk to your dealer about possible certification options (i.e. Tier 3/Stage 3A, Tier 4/Stage 3B, Tier 4F / Stage 4).

**Product Conveyor**

Width: 1000mm (39")  
Discharge height: 3.30m (10'10")

**Independent Pre-Screen**

Single deck hydraulically folding pre-screen  
Length: 3.5m (11'6")  
Width: 2.3m (7'6")  
Capacity: 6m³ (7.8yds³)

**Crusher**

Automax® cone crusher with all roller bearing design  
Size (head diameter): 1150mm (45")  
Concave standard: Medium coarse  
Min CSS: 18mm (0.7")\*  
Max feed size: 180mm (7.1")\*

**Feed Conveyor**

Width: 1200mm (47")  
Over and under belt metal detector

**Hopper**

Wear resistant feed hopper with crash bars  
Length: 3.5m (11'6")  
Width: 2.25m (7'5")  
Capacity: 6m³ (7.8yds³)

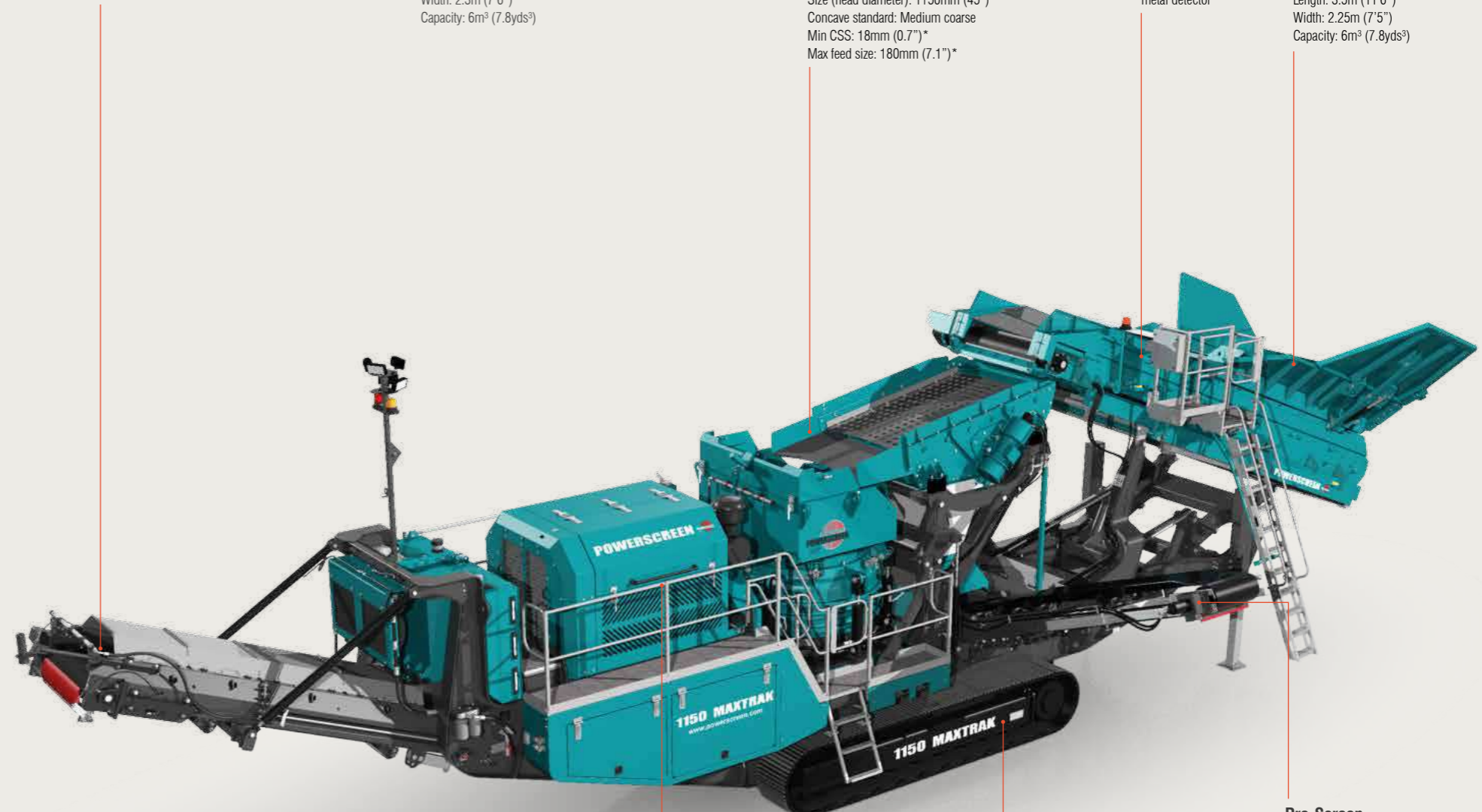

**Pre-Screen Bypass Conveyor**

Width: 650mm (26")  
Discharge height: 2.8m (9'2")

**Power Unit**

Tier 3/Stage 3A: CAT C13 328kW (440hp)  
Tier 4F/Stage 4: Scania DC13 331kW (450hp)  
Fuel tank capacity: 1000 L (264 US Gal)

**Tracks**

Width: 500mm (20")  
2 Speed tracking



# 1300 MAXTRAK

The Powerscreen® 1300 Maxtrak is a medium to large sized track mobile cone crusher which is ideally suited to secondary applications such as taking an all in feed from a primary crusher. Based around the 1300 Automax® cone crusher, the plant excels in the production of sub-base or aggregates, providing excellent cubicity, throughput and reduction ratios.

**Features & Benefits**

- Renowned Automax® crusher technology
- Accepts clean all in feed
- Excellent product shape
- High reduction ratio
- Cone feed box level control to maintain choke feeding
- Hydraulic crusher setting
- Cone overload protection
- Heavy duty chassis and track frame
- Metal detector
- Dust suppression system
- Economical to operate with a highly fuel efficient direct drive system
- Fitted with Powerscreen Pulse Telematics system

**Options**

- Concave: medium coarse, Autosand®
- Feed hopper extension plates
- Product conveyor belt weigher
- Electric refuelling pump
- Hydraulic water pump
- Urea refuelling pump
- Radio remote control

**Applications**

- Sand & gravel
- Blasted rock
- River rock
- C & D waste
- Foundry waste
- Processed ores

**Product Conveyor**

Width: 1000mm (39")  
 Discharge height: 3.4m (11'2")  
 Dust suppression

**Crusher**

Automax® cone crusher with all roller bearing design  
 Size (head diameter): 1300mm (51")  
 Concave standard: Medium coarse  
 Min. CSS: 24mm (1")\*  
 Max. CSS: 44mm (1.75")\*  
 Max. feed size: 220mm (8.5")

**Feed Conveyor**

Width: 1300mm (51")  
 Over and under belt metal detector

**Hopper**

Wear resistant feed hopper with crash bars  
 Length: 3.5m (11'4")  
 Width: 2.8m (9'2")  
 Capacity: 7m³ (9.1yds³)



**Power Unit**

Tier 3/Stage 3A:  
 CAT C13 ACERT 328kW (440hp)  
 Tier 4/Stage 4:  
 Scania DC13 84A 331kW (450hp)  
 Fuel tank capacity: 1000 L (264 US Gal)

**Tracks**

Width: 500mm (20")

**1300 MAXTRAK**

Weight (Est) (Tier 3)	48,020kg (105,865lbs)
Weight (Est) (Tier 4)	47,880kg (105,557 lbs)
Transport width	3m (9'10")
Transport length	15.35m (40'4")
Transport height	3.85m (12'8")
Working width	3.85m (12'8")
Working length	15.5m (50'10")
Working height	4.7m (15'5")



\*Depends on application  
 Engines are available that are certified to US EPA and EU off road diesel emission standards. Talk to your dealer about possible certification options (i.e. Tier 3/Stage 3A, Tier 4/Stage 3B, Tier 4F / Stage 4).



# 1400 MAXTRAK

The Powerscreen® 1400 Maxtrak is a medium to large sized track mobile cone crusher which is ideally suited to secondary applications such as taking an all in feed from a primary crusher. Based around the Terex 1380mm cone chamber, the plant excels in the production of sub-base or aggregates, providing excellent cubicity, throughput and reduction ratios.

**Features & Benefits**

- Excellent product shape
- High reduction ratio
- Cone feed box level control to maintain choke feeding
- Hydraulic crusher setting
- Cone overload protection
- Heavy duty chassis and track frame
- Metal detector
- Dust suppression system
- Economical to operate with a highly fuel efficient direct drive system
- Maintenance free hydraulic anti-spin clutch helping improve liner wear life
- Fitted with Powerscreen Pulse Telematics system

**Options**

- Concave: medium coarse
- Feed hopper extension plates
- Product conveyor belt weigher
- Electric refuelling pump
- Hydraulic water pump
- Urea refuelling pump
- Radio remote control
- Hydraulic extensions for feed hopper

**Applications**

- Sand & gravel
- Blasted rock
- River rock
- C & D waste
- Foundry waste
- Processed ores

**Product Conveyor**

Width: 1200mm (47")  
 Discharge height: 3.55m (11'8")  
 Dust suppression

**Crusher**

Terex MVP450x cone chamber  
 Size (head diameter): 1380mm (54")  
 Concave standard: Medium coarse  
 Min. CSS: 6mm (0.2")  
 Max. CSS: 75mm (3")  
 Max. feed size: 255mm (10")

**Feed Conveyor**

1200mm (47")  
 Over and under belt metal detector

**Hopper**

Wear resistant feed hopper with crash bars  
 Length: 6m  
 Width: 2.5m (8'2")  
 Capacity: 8m³ (10.4yds³)



**Power Unit**

Tier 3/Stage 3A:  
 CAT C18 ACERT 575KW (770hp)  
 Fuel tank capacity: 1100 L (290 US Gal)

**Tracks**

Width: 500mm (20")

**1400 MAXTRAK**

Weight (Est)	61,000kg (134,482lbs)
Transport width	3m (9'10")
Transport length	17m (55'6")
Transport height	3.8m (12'6")
Working width	4.18m (13'9")
Working length	18.5m (60'8")
Working height	6m (19'8")

\*Depends on application  
 Engines are available that are certified to US EPA and EU off road diesel emission standards. Talk to your dealer about possible certification options (i.e. Tier 3/Stage 3A, Tier 4/Stage 3B, Tier 4F / Stage 4).



# 1500 MAXTRAK

The Powerscreen® 1500 Maxtrak is one of the largest mobile cone crushers on the market. Specifically developed for larger users, The plant can accept an all in feed from a primary crusher and has been specifically developed for operators processing large volumes of material.

With the Powerscreen® 1500 Automax® cone crusher, operators benefit from hydraulic overload protection, a large throughput, excellent product cubicity and a high reduction ratio.

### Features & Benefits

- Renowned Automax® crusher technology
- Excellent product shape
- Accepts clean all in feed
- High reduction ratio
- Cone feed box level control to maintain choke feeding
- Hydraulic crusher setting
- Cone overload protection
- Heavy duty chassis and track frame
- Large feed hopper with folding sides, wear resistant liners and crash box
- Feed conveyor folds for maintenance, remove for transport
- Metal detector comes with contaminated material dump facility
- Dust suppression system
- Electric refuelling pump
- Plant lighting
- User friendly and intelligent PLC control system
- Economical to operate with a fuel efficient direct crusher drive via wet clutch
- Fitted with Powerscreen Pulse Telematics system

### Options

- Fine concave
  - Product conveyor belt weigher
  - Hydraulic water pump
  - Radio remote control
  - Crusher mounted camera – displayed on control panel
- Feed conveyor transported separately.  
Weight 12,000kg (26460lbs)

### Applications

- Sand & gravel
- Blasted rock
- River rock
- C & D waste
- Foundry waste
- Processed ores
- Processed minerals

### Product Conveyor

Width: 1400mm (55")  
Discharge height: 4.65m (15'3")  
Dust suppression

### Crusher

Automax® cone crusher with all roller bearing design  
Size (head diameter): 1500mm (59")  
Concave standard: Coarse  
Min CSS: 35mm (1.4")\*  
Max CSS: 64mm (2.5")\*

### Feed Conveyor

Width: 1500mm (59")  
Over and under belt metal detector

### Hopper

Wear resistant feed hopper with crash bars  
Length: 3.3m (10'10")  
Width: 4.25m (13'11")  
Capacity: 9m³ (11.8yds³)

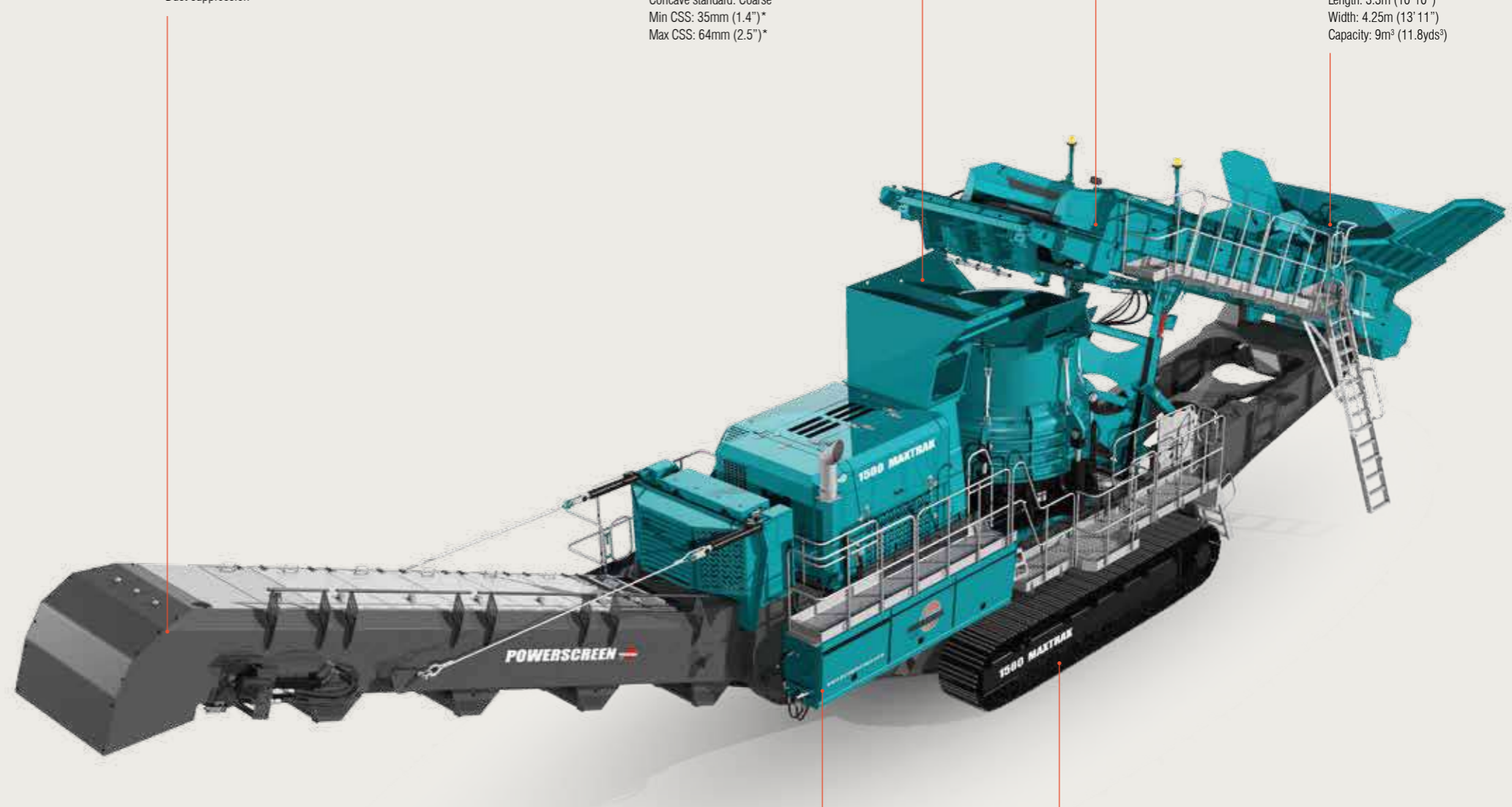

### 1500 MAXTRAK

Weight (Est)	89,000kg (196,211lbs)
Transport width	3.5m (11'6")
Transport length	22m (72'6")
Transport height	3.85m (12'8")
Working width	5.1m (16'9")
Working length	23.9m (79'9")
Working height	6.2m (20'8")



\*Depends on application

Engines are available that are certified to US EPA and EU off road diesel emission standards. Talk to your dealer about possible certification options (i.e. Tier 3/Stage 3A, Tier 4/Stage 3B, Tier 4F / Stage 4).

### Power Unit

Tier 3/Stage 3A:  
CAT C18 ACERT 470kW (630hp)  
Fuel tank capacity: 1000 L (264 US Gal)

### Tracks

Width: 600mm (24")

Engines are available to meet US EPA emission standards under CFR 1039.625 and EU Flexibility provisions of Directive 97/68/EC



# TRAKPACTOR 260

The Powerscreen® Trakpactor 260 horizontal shaft impactor is a compact track mobile crusher designed for the recycling and demolition markets. Capable of processing a wide range of material at a high output, the plant is versatile, easy to operate and fuel efficient due to its direct drive system.

Featuring the Powerscreen® Trakpactor 260 fixed hammer horizontal impactor, the plant offers users both excellent reduction and a high consistency of product shape alongside key features such as hydraulic overload protection.

**Features & Benefits**

- Replaceable tine bar cartridge style grizzly feeder
- Load management system to control feeder speed
- Crusher chamber: Patented hydraulic overload protection and adjustment system.
- 4 Bar rotor and twin apron design
- Economical to operate with HPTO clutch & highly fuel efficient direct drive system
- Crusher speed and conveyor height controlled with user-friendly PLC system
- Modular conveyor with raise/lower facility to aid clearance of rebar
- Dust suppression system
- Fitted with Powerscreen Pulse Telematics system

**Options**

- Full and half size chrome, martensitic and ceramic blow bars
- 4 full size hammers in lieu of 2 full & 2 half hammers
- Various tine bar apertures
- Grizzly blanking mats
- Wire mesh for underscreen
- Single pole/twin pole magnet
- Belt scale
- Bypass conveyor
- Electric refuelling pump
- Plant lighting
- Radio remote control
- Hot/cold climate oil kits
- Blow bar removal tool
- Control panel positive pressurisation
- Fully independent under crusher vibrating pan feeder

**Applications**

- Blasted rock
- River rock
- C & D waste
- Foundry waste
- Processed ores
- Processed minerals

**TRAKPACTOR 260**

Weight (Est)	27,000kg (59,525lbs) with bypass conveyor & magnet
Transport width	2.5m (8'2")
Transport length	13.4m (43'10")
Transport height	3.2m (10'6")
Working width	4m (13'1") with bypass conveyor
Working length	13.4m (43'10")
Working height	3.6m (11'10")



\*Depends on application  
Engines are available that are certified to US EPA and EU off road diesel emission standards. Talk to your dealer about possible certification options (i.e. Tier 3/Stage 3A, Tier 4/Stage 3B, Tier 4F / Stage 4).

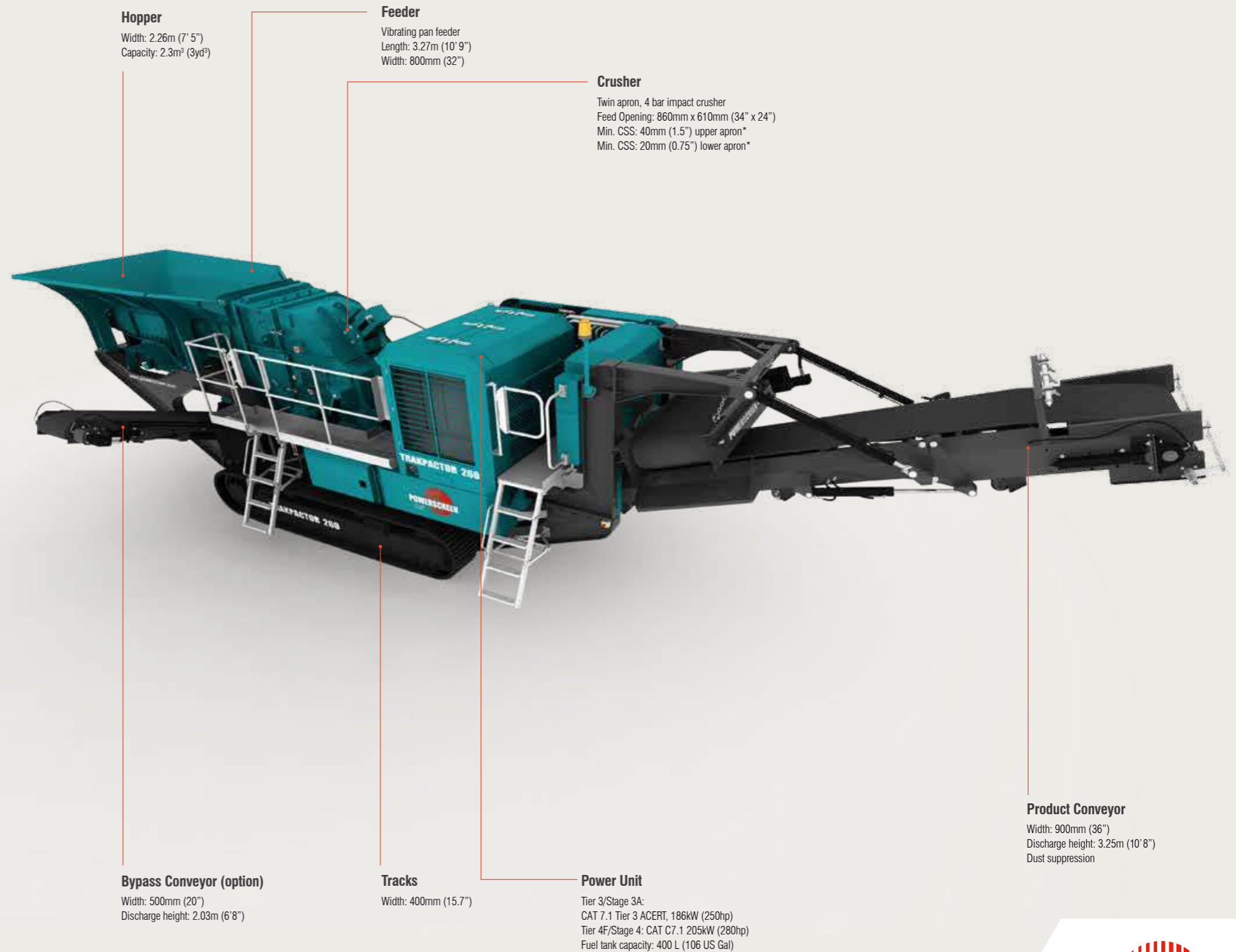

# TRAKPACTOR 260SR

The Powerscreen® Trakpactor 260SR horizontal shaft impactor is a compact track mobile crusher designed for the recycling and demolition markets. Capable of processing a wide range of material at a high output, the plant is versatile, easy to operate and fuel efficient due to its direct drive system.

Featuring the Powerscreen® Trakpactor 260SR fixed hammer horizontal impactor, the plant offers users both excellent reduction and a high consistency of product shape alongside key features such as hydraulic overload protection.

### Features & Benefits

- Replaceable tine bar cartridge style grizzly feeder
- Load management system to control feeder speed
- Crusher chamber: Patented hydraulic overload protection and adjustment system.
- 4 Bar rotor and twin apron design
- Economical to operate with HPTO clutch & highly fuel efficient direct drive system
- Crusher speed and conveyor height controlled with user-friendly PLC system
- Modular conveyor with raise/lower facility to aid clearance of rebar
- Dust suppression system
- Quick-detach post-screen to convert to standard Trakpactor 260
- Recirculating conveyor
- Fitted with Powerscreen Pulse Telematics system

### Options

- Full and half size chrome, martensitic and ceramic blow bars
- 4 full size hammers in lieu of 2 full & 2 half hammers
- Various tine bar apertures
- Grizzly blanking mats
- Wire mesh for underscreen
- Single pole/twin pole magnet
- Belt scale
- Bypass conveyor
- Electric refuelling pump
- Plant lighting
- Radio remote control
- Hot/cold climate oil kits
- Blow Bar removal tool
- Control panel positive pressurisation
- Fully independent under crusher vibrating pan feeder

### Applications

- Blasted rock
- River rock
- C & D waste
- Foundry waste
- Processed ores
- Processed minerals

### TRAKPACTOR 260SR

Weight (Est)	33,950kg (74,847lbs) with bypass conveyor & magnet
Transport width	3m (9'10")
Transport length	14.8m (48'6")
Transport height	3.2m (10'6")
Working width	5.5m (18')
Working length	15.8m (51'8")
Working height	3.86m (12'7")

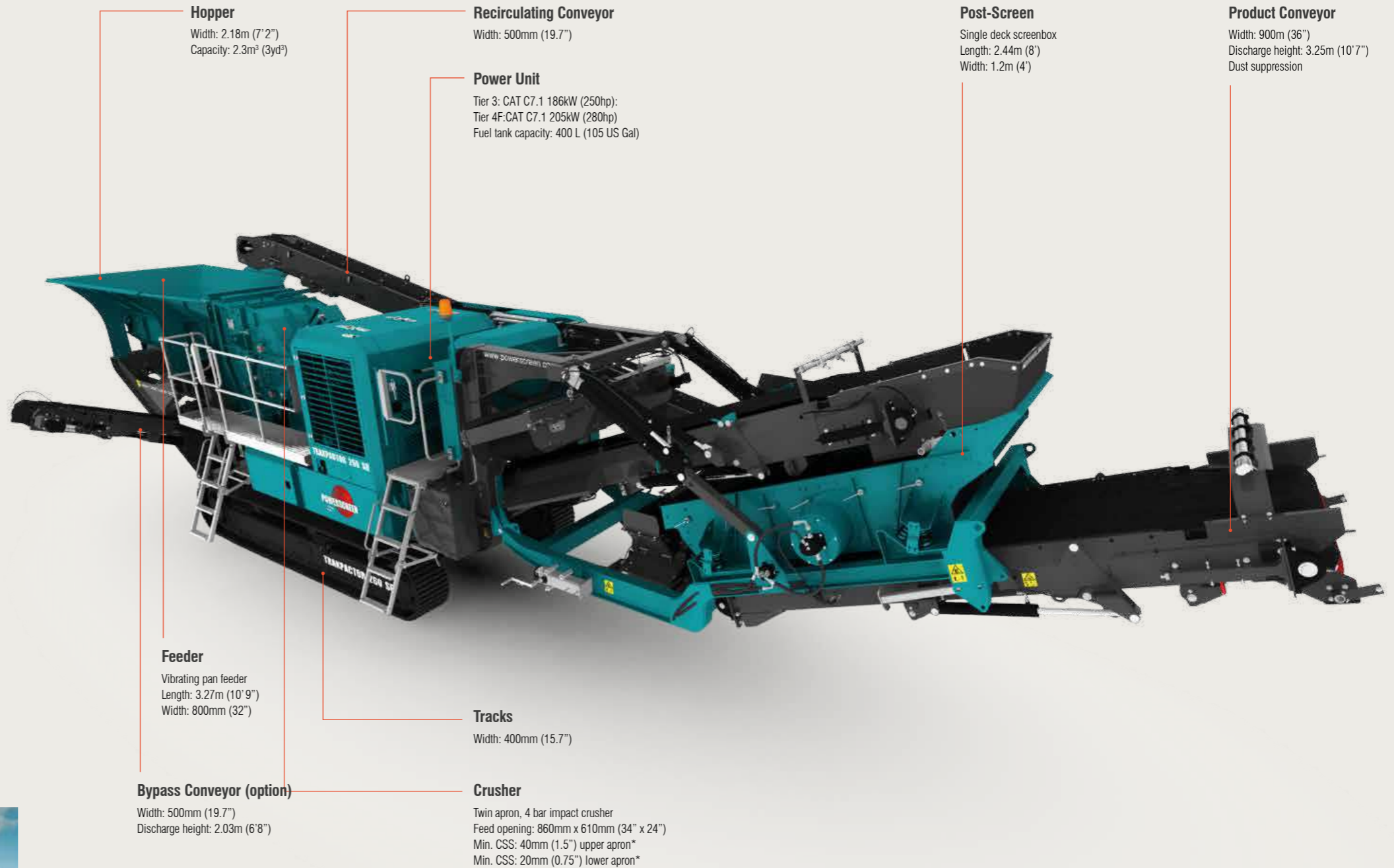

\*Depends on application  
Engines are available that are certified to US EPA and EU off road diesel emission standards. Talk to your dealer about possible certification options (i.e. Tier 3/Stage 3A, Tier 4/Stage 3B, Tier 4F / Stage 4).



# TRAKPACTOR 320

The Powerscreen® Trakpactor 320 is a mid-sized horizontal impact crusher with a fully independent hydraulic driven pre-screen. It has been designed to offer operators and contractors both excellent reduction and high consistency of product shape for performance in quarry and recycling applications while also improving fines removal and reduce chamber wear costs for the customer. With track mobility the plant is capable of working in the most demanding environments and features a rapid set-up time, fuel efficient direct drive system and excellent throughput capacity.

**Features & Benefits**

- Suitable for a variety of feed materials including recycling, demolition & quarry applications
- Crusher chamber: Patented hydraulic overload protection and adjustment system.
- Bolt in cartridge grizzly – 42mm nominal spacing
- Load management system to control feeder speed
- 4 Bar rotor & twin apron design
- Crusher speed variation through user friendly PLC control system
- Modular conveyor with raise/lower facility to aid clearance of rebar
- Economical to operate with a highly fuel efficient direct drive system
- Double deck grizzly feeder with under screen
- Fitted with Powerscreen Pulse Telematics system

**Options**

- Full & half size chrome, martensitic, austenitic & ceramic blow bars
- Grizzly cartridges
- Independent hydraulic pre-screen with hydraulic folding and locking hopper.
- Underpan feeder
- Pre-screen cassettes – punch plate and grizzly
- Punch plate options
- Blanking plates/mats for grizzly
- Wire mesh for feeder underscreen
- Single pole/twin pole magnet
- Belt scale
- Refuelling pump
- Hydraulic water pump
- Radio remote control
- Dust hood on product conveyor
- Plant lighting
- Hopper extensions
- Bypass conveyor & extended bypass conveyor
- Extended product conveyor

**Applications**

- Blasted rock
- River rock
- C & D waste
- Foundry waste
- Processed ores
- Processed minerals

**TRAKPACTOR 320**

Weight (Est)	35,280kg (77,779lbs)
Transport width	2.55m (8'4")
Transport length	14.78m (48'6")
Transport height	3.46m (11'4")
Working width	5.61m (18'5") with bypass conveyor
Working length	14.36m (47'1")
Working height	3.9m (12'10")



\*Depends on application  
Engines are available that are certified to US EPA and EU off road diesel emission standards. Talk to your dealer about possible certification options (i.e. Tier 3/Stage 3A, Tier 4/Stage 3B, Tier 4F / Stage 4).

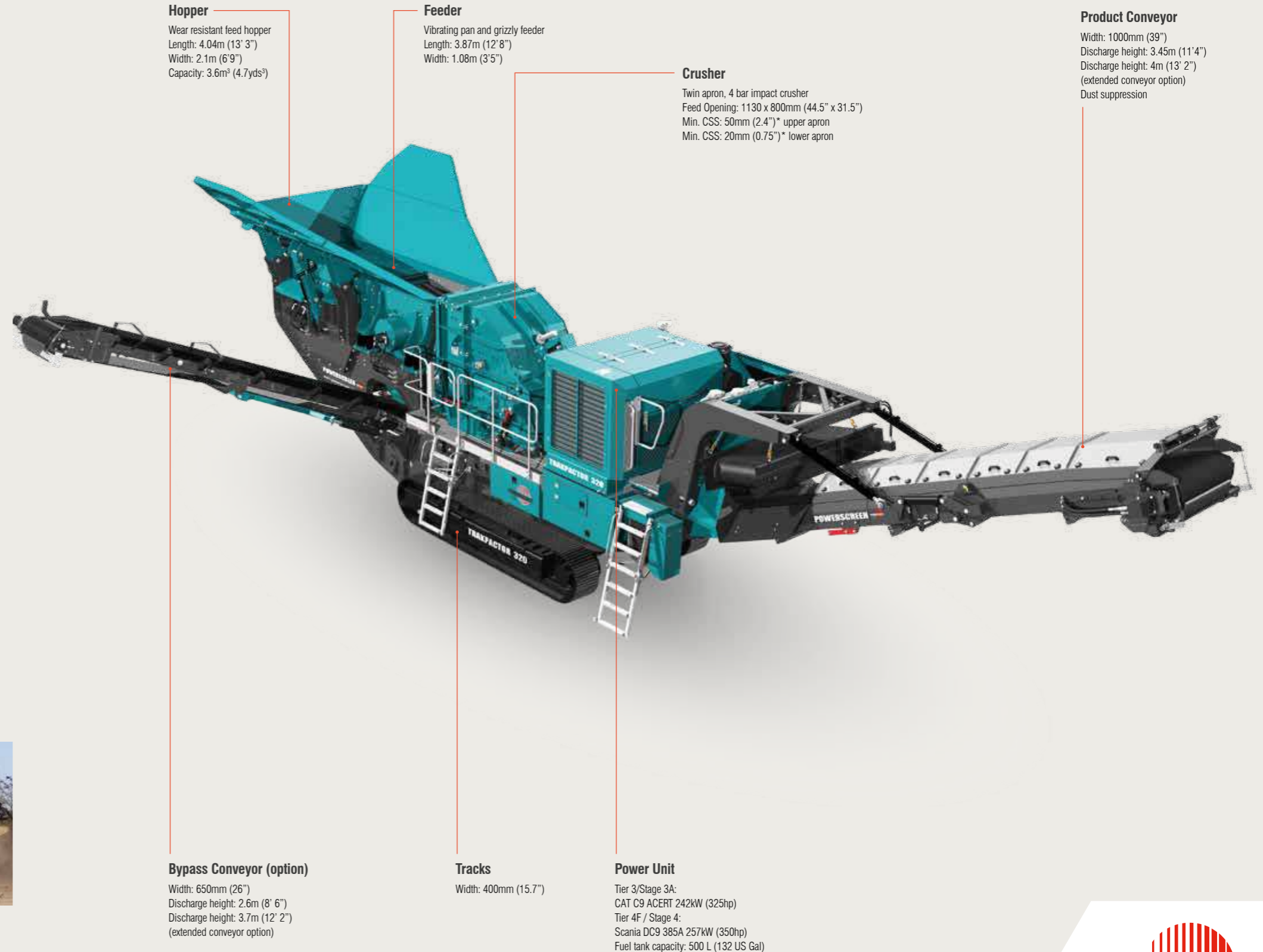

# TRAKPACTOR 320SR

The Trakpactor 320SR is a mid-sized horizontal impact crusher redesigned with some key enhancements to offer operators and contractors excellent reduction and high consistency of product shape for performance in quarry and recycling applications.

The plant is capable of working in the most demanding environments and features rapid set-up time, fuel efficient direct drive system and excellent output potential of up to 320 tph (352 US tph). The plant features a quick-detach post-screen section which converts it to a standard Trakpactor 320 unit. Another key feature is the recirculating conveyor which raises for transport allowing more ground clearance under the machine when moving on site and while loading for transport.

**Features & Benefits**

- Crusher chamber: Patented hydraulic overload protection and adjustment system.
- Bolt in cartridge grizzly – 42mm nominal spacing
- Load management system to control feeder speed
- Crusher speed variation through user friendly PLC control system
- Modular conveyor with raise/lower facility to aid clearance of rebar
- Economical to operate with a highly fuel efficient direct drive system
- Patented double deck post-screen.
- Quick-detach post-screen to convert to standard Trakpactor 320
- Recirculating conveyor with hydraulic raise for transport
- Hydraulically assisted CSS adjustment
- 4 Bar rotor & twin apron impactor chamber
- Fitted with Powerscreen Pulse Telematics system

**Options**

- Full & half size chrome, martensitic, austenitic & ceramic blow bars
- Grizzly cartridges
- Independent hydraulic pre-screen with hydraulic folding & locking hopper.
- Pre-screen cassettes – punch plate & grizzly
- Punch plate options
- Blanking plates/mats for grizzly
- Wire mesh for feeder underscreen
- Single pole/twin pole magnet
- Belt scale
- Refuelling pump
- Hydraulic water pump
- Radio remote control
- Plant lighting
- Hopper extensions
- Bypass conveyor & extended bypass conveyor.
- Extended product conveyor
- Grinding path
- Hydraulically folding mid-grade conveyor
- Hydraulic overload protection

**Applications**

- Blasted rock
- River rock
- C & D waste
- Foundry waste
- Processed ores
- Processed minerals

**TRAKPACTOR 320SR**

Weight (Est)	46,240kg (101,941lbs) (Vibrating Grizzly Feeder) 48,600kg (107,144lbs) (Pre-Screen)
Transport width	3.1m (10'2")
Transport length	17.58m (57'8")
Transport height	3.4m (11'2")
Working width	5.82m (19'1") with bypass conveyor
Working length	17.22m (56'6")
Working height	4.7m (15'5")



\*Depends on application  
Engines are available that are certified to US EPA and EU off road diesel emission standards. Talk to your dealer about possible certification options (i.e. Tier 3/Stage 3A, Tier 4/Stage 3B, Tier 4F / Stage 4).

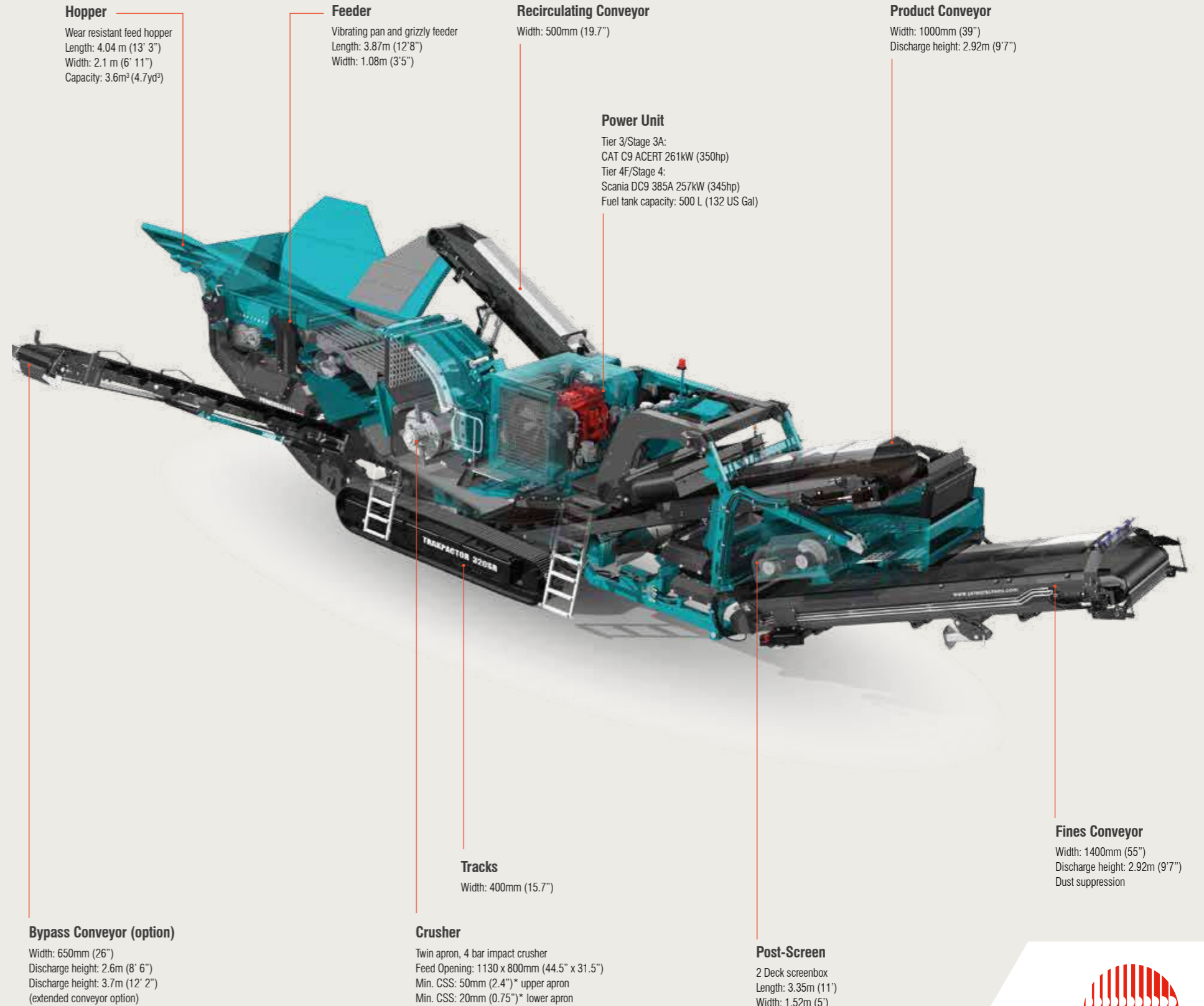

# TRAKPACTOR 550

The Powerscreen® Trakpactor 550 is a horizontal shaft impactor which is versatile, efficient and highly productive. It offers both excellent reduction and a high consistency of product yield in quarrying, recycling and demolition applications. The machine has been designed with excellent material flow and serviceability in mind. In addition, the machine can be configured for work safely and in record time as set-up is all carried out at ground level.

The robust Terex impact chamber features c-shaped blowbars as standard for better impact and a time-saving hydraulic adjust option.

### Features & Benefits

- Suitable for a variety of feed materials including recycling, demolition & quarry applications
- Double deck grizzly feeder with under screen
- Impact crusher with hydraulic overload protection
- 4 Bar rotor with twin apron design
- Crusher speed variation through user friendly PLC control system
- Modular conveyor with raise/lower facility to aid clearance of rebar
- Economical to operate with a chamber drive via clutch & highly fuel efficient direct drive system
- Full length conveyor "under belt version"
- New Terex Chamber
- Fitted with Powerscreen Pulse Telematics system
- Efficient load sensing hydraulic system for better fuel efficiency
- Terex design underpan
- Low level battery access
- Designated hydraulic cabinet

### Options

- Full & half size martensitic, austenitic, chrome, ceramic blow bars
- Vibrating grizzly feeder
- 4 Full size blow bars in lieu of 2 full 2 half blow bars
- Blow bar crane
- Wire mesh for grizzly underscreen
- Belt weigher
- Overband magnet
- Bypass conveyor
- Electric refuelling pump
- Hydraulic driven water pump
- Radio remote control
- 2 Deck live pre-screen
- Plant lighting
- Fully independent under crusher vibrating pan feeder
- Positive air pressure control cabinet
- Small pulley wheel for slower rotor tip speeds
- Constant speed engine (EU only)
- Hazemag 1214 Chamber
- Product conveyors dust covers
- Auto adjust (Terex chamber only)
- Reversible fan
- Fuel active diesel delivery system
- Bolt on extended hopper

### Applications

- Blasted rock
- River rock
- C & D waste
- Foundry waste
- Processed ores
- Processed minerals

### TRAKPACTOR 550

Weight (Est)	54,850kg (115,919lbs) with bypass conveyor & magnet (excluding pre-screen)
Transport width	3m (9'10")
Transport length	17.46m (57'3")
Transport height	3.8m (12'6")
Working width	3m (9'10") 6.96m (22'10") with bypass conveyor
Working length	18.6m (61')
Working height	5.15m (16'9") with hopper extensions



### Hopper

Wear resistant feed hopper  
Length: 4.87m (15'12")  
Width: 2.62m (8'7")  
Capacity: 7m³ (9.2yds³)

### Feeder

Vibrating pan and grizzly feeder  
Length: 4.3m (14'1")  
Width: 1.26m (4'2")  
Grizzly length: 2m (6'6")

### Crusher

Twin apron, 4 bar impact crusher  
Feed Opening: 1370mm x 911mm (54" x 36")  
Min. CSS: 75mm (3")\* upper apron  
Min. CSS: 35mm (1.4") lower apron

### Bypass Conveyor (option)

Width: 800mm (32")  
Discharge height: 3.2m (10'6")



### Power Unit

Tier 3/Stage 3A:  
CAT C13 ACERT 328kW (440hp)  
Tier 4F/Stage 4:  
Scania DC13 373kW (500hp)  
Fuel tank capacity: 1000 L (264 US Gal)

### Tracks

Width: 500mm (20")

### Product Conveyor

Width: 1200mm (47")  
Discharge height: 3.8m (12'6")

\*Depends on application

Engines are available that are certified to US EPA and EU off road diesel emission standards. Talk to your dealer about possible certification options (i.e. Tier 3/Stage 3A, Tier 4F / Stage 4, Constant speed).



# TRAKPACTOR 550SR

The NEW high performance Trakpactor 550SR is the flagship impactor of the Powerscreen range. It is designed for processing soft to medium-hard primary and secondary materials such as natural rock and construction derived materials such as asphalt, recycling and demolition waste.

The plant has been designed with ease of maintenance in mind. Hydraulic banks, battery access and control valves are at eye level to make setup and operation much easier. The SR section is fully detachable using quick release hydraulics and electrics. The recirculating conveyor can also slew from recirculation to stockpiling position giving an incredibly impressive 5.43m (17' 10") stockpile height.

### Features & Benefits

- NEW Recirculating conveyor slews hydraulically from recirculation to stockpiling mode
- Converts to Trakpactor 550 in minutes thanks to quick-detach SR section. Ideal for regions with transport weight restrictions
- Excellent access features for serviceability eg. hydraulic cabinet at ground level; unrestricted access to both sides of power unit; steel pipes in key locations
- Low level set-up removes requirement for working at height maximising machine uptime
- Enhanced material flow features increases productivity
- Direct drive via Desch gearbox provides machine fuel efficiency
- Start up motor for smooth engagement and increasing clutch life
- Powerscreen Pulse intelligent monitoring as standard

### Options

- Full & half size martenitic, austenitic, chrome, ceramic blow bars
- Vibrating grizzly feeder
- 4 Full size blow bars in lieu of 2 full 2 half blow bars
- Blow bar crane
- Wire mesh for grizzly underscreen
- Optical belt scale
- Single pole/twin pole magnet
- Bypass conveyor
- Electric refuelling pump
- Hydraulic driven water pump
- Radio remote control
- 2 Deck live pre-screen
- Single deck post-screen
- Plant lighting
- Fully independent under crusher vibrating pan feeder

### Applications

- Blasted rock
- River rock
- C & D waste
- Foundry waste
- Processed ores
- Processed minerals

### TRAKPACTOR 550SR

Weight (Est)	66,800kg (147,269lbs) (VGF, Terex chamber, full length product conveyor, bypass conveyor & magnet)
Weight (Est)	72,000kg (158,733bs) (Constant speed engine, independent pre-screen, hopper extensions, Hazemag chamber, underpan feeder, bypass conveyor & magnet)
Transport width	3.45m (11' 4")
Transport length	21.1m (69' 1")
Transport height	3.8m (12' 6")
Working width	6.88m (22' 7") with bypass conveyor
Working length	20.6m (67' 7")
Working height	5.83m (19' 2")

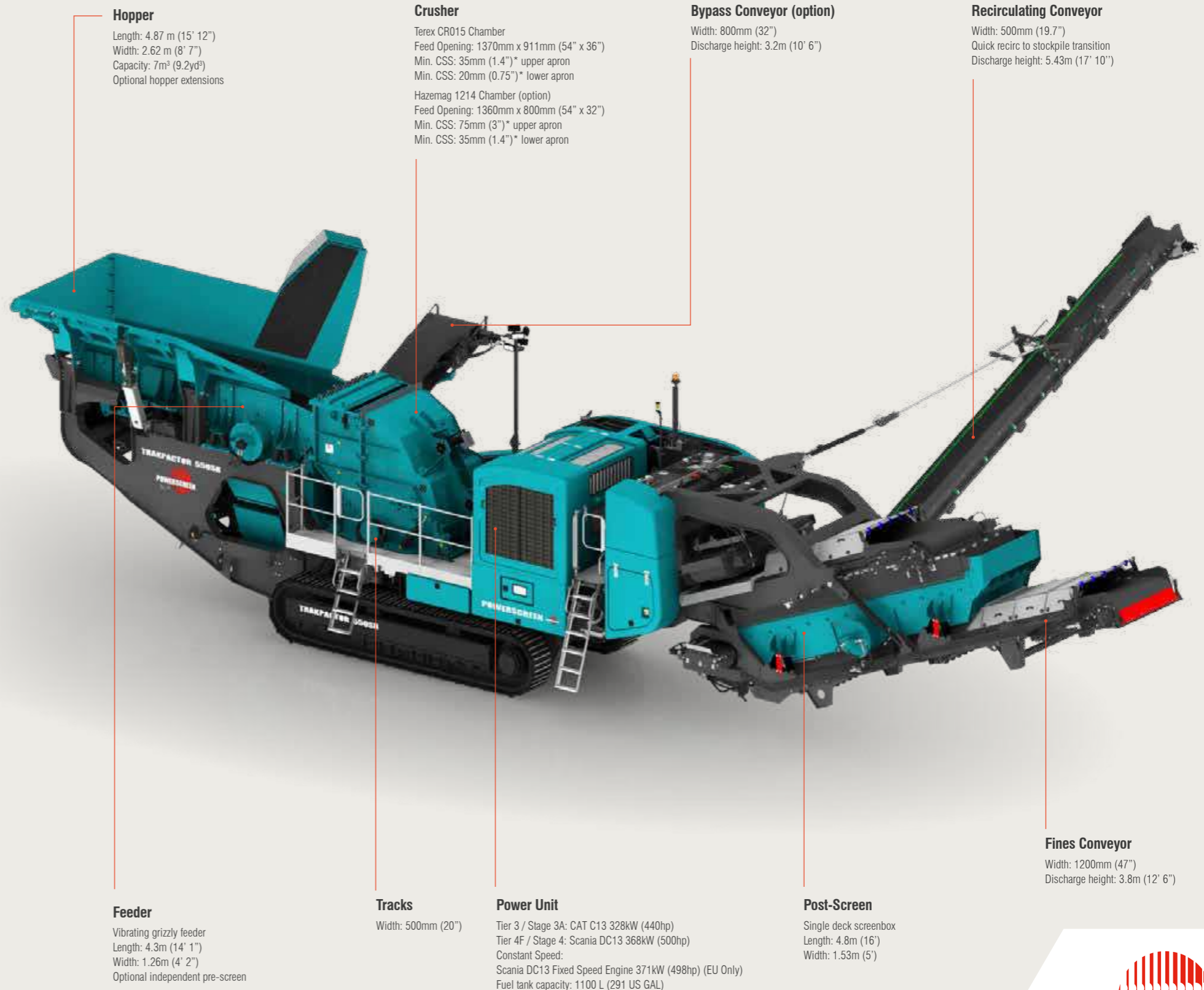

\*Depends on application  
Engines are available that are certified to US EPA and EU off road diesel emission standards. Talk to your dealer about possible certification options (i.e. Tier 3/Stage 3A, Tier 4/Stage 3B, Tier 4F / Stage 4).



# XV350

The Powerscreen® XV350 vertical shaft impactor is designed for users requiring a plant that excels at producing high specification, shaped products.

Numerous crushing configurations allow the versatile XV350 to produce materials suitable for applications including road building, concrete manufacture, manufactured sand, slag, and glass recycling.

**Features & Benefits**

- Exceptionally versatile due to interchangeable crushing configurations
- Excellent product shape
- Economical to operate with a highly fuel efficient direct drive system
- Proven Terex® Canica 2050 VSI crusher
- Hydraulic lid lift mechanism for quick and safe maintenance of wear parts
- Feed regulator for optimum feeding which stops the feed belt if a blockage occurs
- Variable speed feed belt
- Automatic crusher lubrication system with temperature and flow analysis
- Hydraulic driven water pump
- Dust suppression system
- Heavy duty fabricated chassis & track frame
- Vibration Sensory Monitoring (VSM)
- Fitted with Powerscreen Pulse Telematics system

**Options**

- Feed hopper extension plates
- Product conveyor belt weigher with speed wheel
- Product conveyor dust hood
- Electric refuelling pump
- Radio remote control

**Applications**

- Sand & gravel
- Blasted rock
- River rock
- C & D waste
- Foundry waste
- Processed ores
- Processed minerals

**Chamber Configuration Options**

- High speed 5 port rotor & rock shelf
- High speed 5 port rotor & drop in anvils
- Heavy duty 4 port rotor & rock shelf
- Heavy duty 4 port rotor & drop in anvils
- Open shoe table & vaulted anvils
- Open shoe table & drop in anvils

Please speak to your local dealer to select the right configuration for your application.

**XV350**

Weight (Est)	36,900kg (81,350lbs)
Transport width	3m (9'10")
Transport length	15.45m (50'8")
Transport height	3.85m (12'8") with folding hopper extensions
Working width	3.85m (12'8")
Working length	15.6m (51'2")
Working height	4.6m (15'1")



\*Depends on application  
Engines are available that are certified to US EPA and EU off road diesel emission standards. Talk to your dealer about possible certification options (i.e. Tier 3/Stage 3A, Tier 4/Stage 3B, Tier 4F / Stage 4).

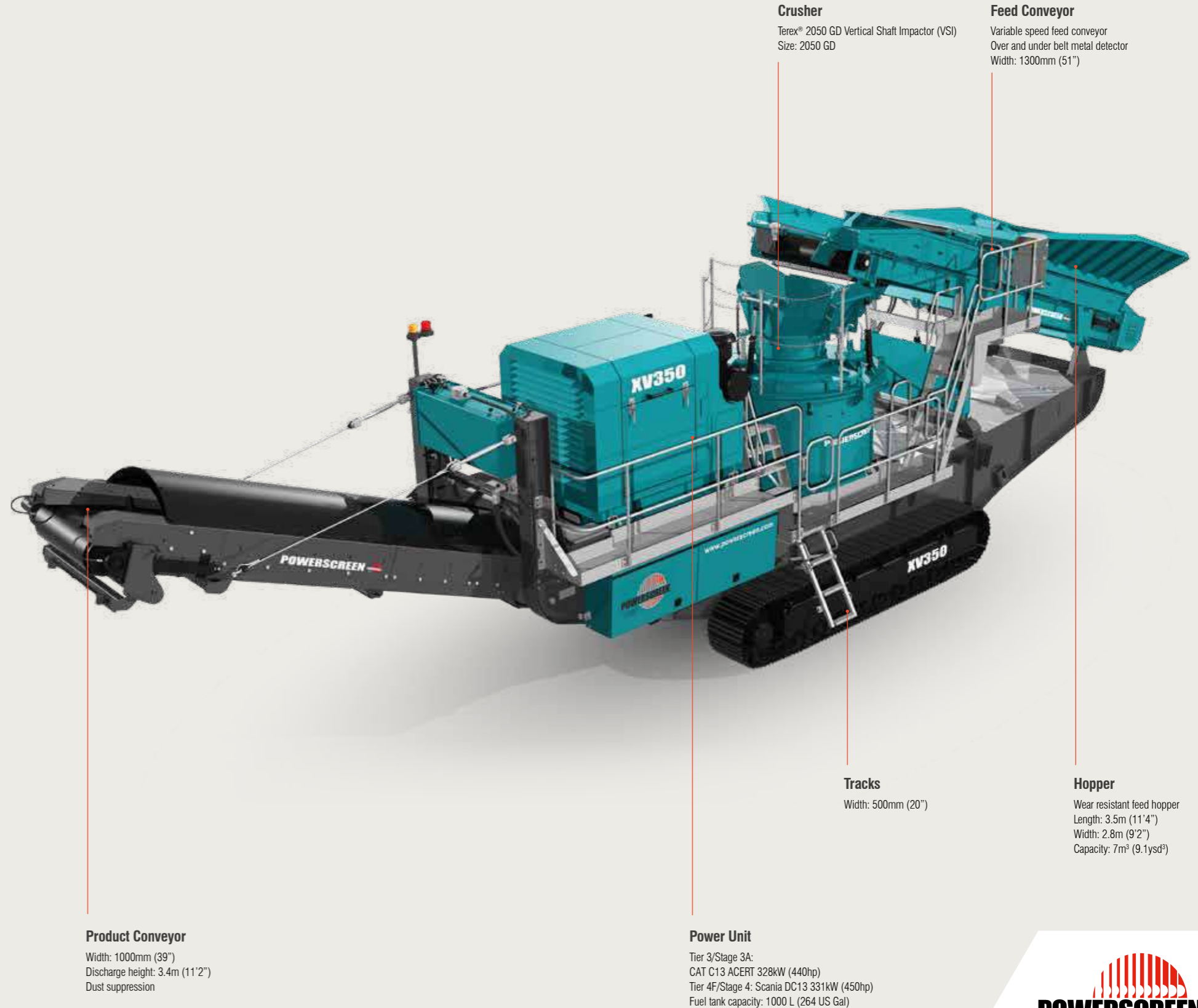

# CRUSHING TECHNOLOGY



## JAW

A range of jaw tooth profiles are available for your Powerscreen Jaw Crusher. This choice allows maximised performance across all applications with excellent wear life and output potential. All Powerscreen jaw plates are fully reversible allowing maximum usage of available plate and are fully machined on locating surfaces providing ease of speed when fitting them. A convenient easy lifting system also facilitates changes. To better understand the best choice of jaw plate profile for your application contact your local dealer.



## CONE

In all crushing equipment the choice of wear parts often has a direct impact on the quality of the end product produced – this is especially true for cone crushers where end product specification and quality is of key importance.

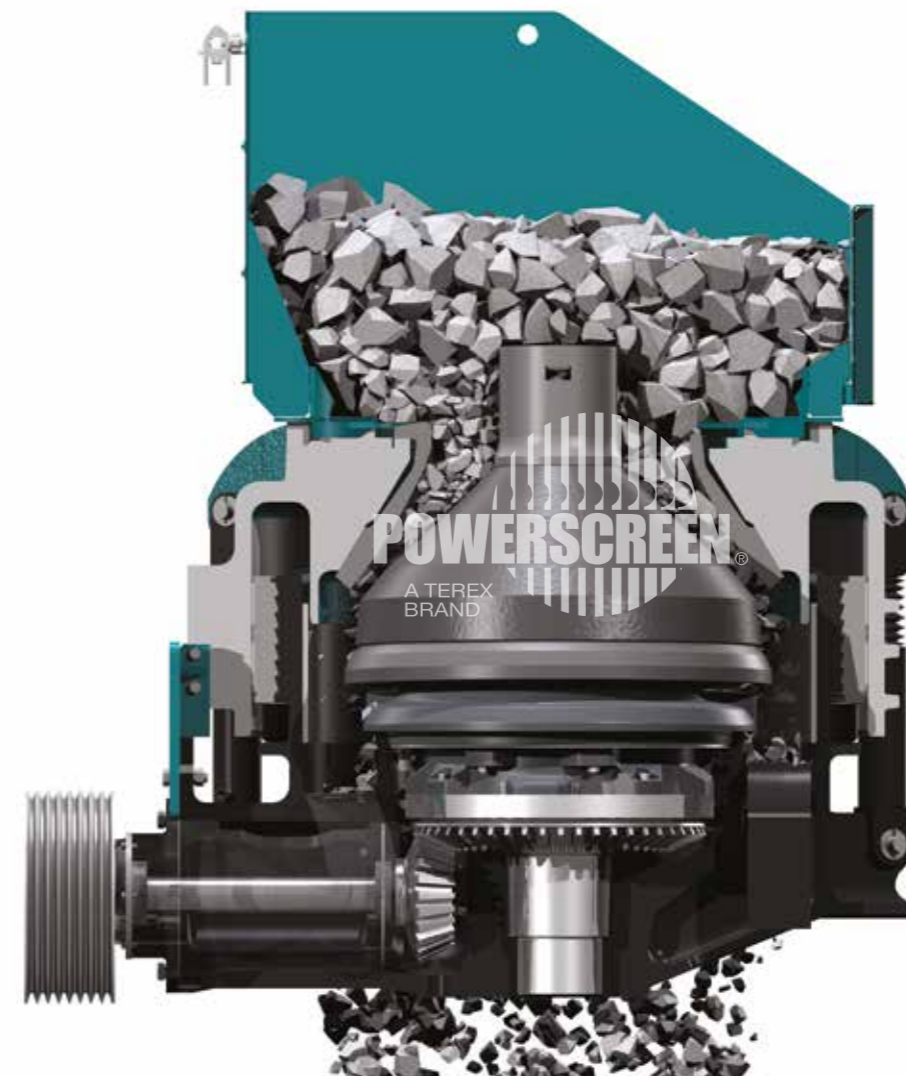



## IMPACTOR

The choice of blow bar for your Powerscreen® impactor is entirely dependent on application – the main factors being: maximum feed size, abrasiveness and hardness of the rock. Powerscreen offers a complete range of blow bar metallurgies to suit all applications, if you are in any doubt about the choice of blow bar to be used contact your local authorised Powerscreen dealer.



## POWERSCREEN® PULSE



### RECORD, DISPLAY AND ANALYSE DATA: HIGH EFFICIENCY THROUGH PRECISE INFORMATION

- Available online anywhere and at any time: comprehensive information on the GPS location, start and stop times, fuel consumption, tonnages, cone settings, wear ratings, operating hours, maintenance status, and much more.
- User-friendly interface: displays information clearly for at a glance metrics and diagnostics. Take action before damage occurs: predetermined maintenance intervals are signaled and error messages are displayed in plain text messages.



#### AVAILABLE ANYWHERE AND AT ANY TIME

- PC
- Tablet
- Smartphone
- Customised notifications

#### DASHBOARD DISPLAY

- Color display of the engine speed, coolant temperature and hydraulic oil temperature as a circular instrument
- Immediate notification of critical statuses

#### MACHINE OVERVIEW

- The status of each machine at a glance (on / off / idle, error message etc.)
- Faults are immediately located and relayed
- Accurate and up-to-date output production tonnages

#### UTILISATION REPORT

- Display of load, idle, and total service life (daily, weekly, or monthly)
- Export available in common formats for data compiling
- Useful for application and fleet planning

#### GPS: MACHINE TRACKING

- Get precise location information and precise application planning
- Geofencing: limiting the range of movement
- Timefencing: limiting operational timings

#### MACHINE DATA

- Detailed display of the current operating data of the machines
- You can take action immediately for adverse operating statuses
- Support for service engineers

#### FUEL CONSUMPTION REPORT

- Generates accurate fuel cost per tonne information
- Under load, idle, and total service life of the machines (daily, weekly, or monthly)
- Support for economic efficiency analysis and for determining saving potential

#### CONE CRUSHER SPECIFIC REPORTING

- Displays Closed Side Settings (CSS)
- Displays wear rates
- Displays number of tramps

# PATENTS

## JAW CRUSHERS

MACHINE	PATENT NUMBER	STATUS
Premiertrak R300	US 9421547B2	Patent granted
	DE 102013210016.7	Patent pending
	GB 1209787.9	Patent pending
Premiertrak 400/R400	FR 1494810	Patent granted
	DE 603 24 905.1-08	Patent granted
	GB 2387342	Patent granted
	US 7341213	Patent granted
	CN ZL03810686.8	Patent granted
Premiertrak 400/R400	CN ZL03810686.8	Patent granted
Premiertrak 400 Pre-Screen	FR 1494810	Patent granted
	DE 603 24 905.1-08	Patent granted
	GB 2387342	Patent granted
	US 7341213	Patent granted
Premiertrak R400 Pre-Screen	CN ZL03810686.8	Patent granted
Premiertrak 400 Pre-Screen	CN ZL03810686.8	Patent granted

## CONE CRUSHERS

MACHINE	PATENT NUMBER	STATUS
1000SR	GB 2386848	Patent granted
	US 6877610	Patent granted
	DE 10305589	Patent granted
1150 Maxtrak	US 9486804	Patent granted
	GB 1210326.3	Patent granted

## IMPACT CRUSHERS

MACHINE	PATENT NUMBER	STATUS
Trakpactor 260	GB 2455203	Patent granted
	US 8033489	Patent granted
	DE 10 2008 044 195	Patent pending
Trakpactor 260SR	GB 2455203	Patent granted
	US 8033489	Patent granted
	DE 10 2008 044 195	Patent pending
Trakpactor 320	GB 2455203	Patent granted
	US 8033489	Patent granted
	DE 10 2008 044 195	Patent pending
Trakpactor 320	DE 10 2008 044 195	Patent pending
	GB 1119480	Patent pending
Trakpactor 320	GB2509291	Patent granted
Trakpactor 320SR	GB 2455203	Patent granted
	US 8033489	Patent granted
	DE 10 2008 044 195	Patent pending
Trakpactor 320SR	GB 2386848	Patent granted
	US 6877610	Patent granted
	DE 10305589	Patent granted
Trakpactor 320SR	GB1220327.9	Patent pending
Trakpactor 320SR	GB2509291	Patent pending
Trakpactor 500SR	DE 10305589	Patent granted



[www.powerscreen.com](http://www.powerscreen.com)

Email: [sales@powerscreen.com](mailto:sales@powerscreen.com)

## POWERSCREEN CONTACT DETAILS

### Dungannon

200 Coalisland Road, Dungannon,  
Co Tyrone, BT71 4DR, Northern Ireland  
Tel: +44 (0) 28 87 718 500  
Fax: +44 (0) 28 87 747 231

### Louisville

11001 Electron Drive,  
Louisville, Kentucky, 40299 USA  
Tel: +1 502 736 5200  
Fax: +1 502 736 5202

## SOCIAL NETWORKING

Become a Powerscreen fan on Facebook by visiting:  
[www.facebook.com/powerscreenofficial](http://www.facebook.com/powerscreenofficial)

Follow Powerscreen on Twitter by visiting:  
[www.twitter.com/powerscreen](http://www.twitter.com/powerscreen)

Follow Powerscreen on LinkedIn:  
[www.linkedin.com/company/powerscreen](http://www.linkedin.com/company/powerscreen)

Check out Powerscreen videos on YouTube:  
[www.youtube.com/powerscreen](http://www.youtube.com/powerscreen)

Get Powerscreen® product information instantly  
with the Powerscreen App for your BlackBerry,  
Android or Apple Mobile Device.

DEALER

The material in this document is for information only and is subject to change without notice.

Powerscreen assumes no liability resulting from errors or omissions in this document, or from the use of the information contained herein. Due to continual product development we reserve the right to change specifications without notice. Product performance figures given in this brochure are for guidance purposes only, this information does not constitute an expressed or implied warranty or guarantee, but shows test examples provided by Dealers. These results will vary depending on crusher chamber settings, screen media and sizes, feed source and types of material being processed.

Photographs are for illustrative purposes only, some or all of the machines in the illustrations may be fitted with optional extras. Please check with your Dealer for details on optional extras.

Powerscreen® is a registered trademark of Terex GB Limited in the United States of America and many other countries. Copyright 2018 Terex GB Limited. Published and Printed in June 2018.

All machines are CE Approved.

