

FM COMPACT[™] RANGE



The Complete FM Compact[™]
Range suitable for all your sand
washing and classification needs.

AGGREGATES



RECYCLING



INDUSTRIAL SANDS



MINING



The Terex FM Compact™ range are static sand washing and classification units designed to be both cost and energy efficient on a single compact chassis. The range utilises centrifugal force within the hydrocyclone(s) to remove clay, silt and slime from sand to bring it into the desired specification. The range combines a collection tank, centrifugal slurry pump(s), hydrocyclone(s) and a dewatering screen to produce up to 2 clean sands.

- Self regulating float level system provides consistent tank volume and pump run-dry protection.
- All slurry pipework is rubber lined to maximise wear life.

- Available wired to isolators or with an optional control panel.
- Optional control panel upgrade for controlling up to 2 stockpile conveyors.

- Linatex Rubber-lined centrifugal pumps with replaceable liners.
- Easy access for all pump and motor maintenance.
- Simple integrated support arm for opening rubber lined pumps.

Model Pictured: FM 200c pump

Model Pictured: FM 200c

- Linatex rubber-lined high efficiency hydrocyclones provides maximum silt and clay (-75µm) removal from the final product.
- Replaceable drop-in liners.
- All models are available equipped with standard G4 hydrocyclones or selected models can have HK separators.

- Linear motion, high frequency dewatering screen delivering superior moisture reduction
- Marshmallow vibration isolation screen mountings.
- E-stops located all around the plant for safe operation.

- Full-width modular polyurethane dewatering media for quick change outs.
- Polyurethane side modules for increased screen protection.
- Low friction discharge chutes with angle adjustments.

- Fully galvanised walkways allowing comprehensive access to the plant.
- Raised chassis design for machine wash down.
- Sloped tank reduces the risk of fines build up.

APPLICATIONS

The FM Compact™ range can produce up to two sands in the following applications:

- All forms of concrete, mortar and asphalt sands
- Quarry dust / crushed fines
- Lake and beach sands
- Silica sand for glass industry
- Golf course sands
- Filter bed sands
- Recycled materials
- Iron ore
- Most materials which need to be washed



Model Pictured: FM 120c - 2G

COMPONENTS

The FM Compact™ range share the following features:

Cyclone

- Application specific sizes for Coarse and fine sands
- Spigot discharge
- All wear areas rubber lined
- Underflow collection box with blending options in 2 grade applications
- Pressure flange with gauge and protector



OPTIONS

The FM Compact™ range can be offered with the following options:

- Boiler box for dry feed
- Electrical control panels with starters for product conveyors
- Dewatering screen spraybars
- Upgrade to C Type and HK separators
- Customized build to double wash dirty material

The range also has the ability to incorporate HK and C-type separators for challenging applications. (For more info please contact your TWS sales representative.)

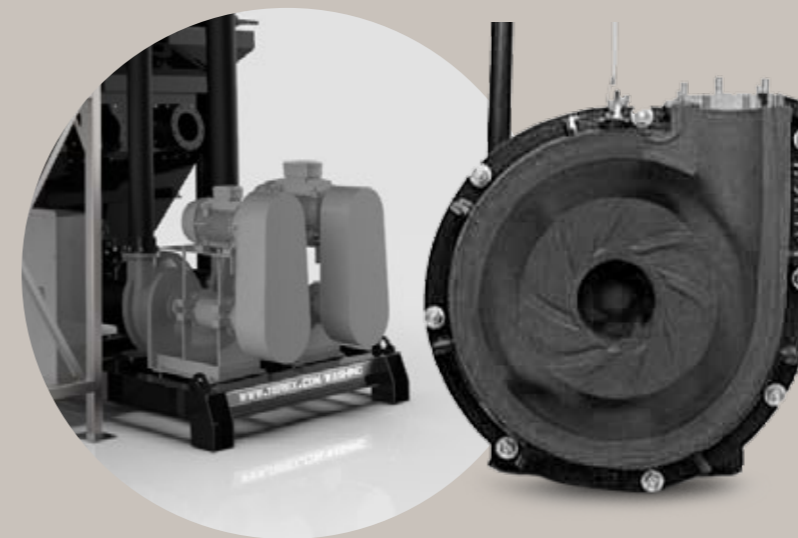

Centrifugal Pumps

- Sized to suit your needs, with numerous combinations of pump and motors
- Abrasion resistant liners
- Moulded rubber impellers
- Pump drain for cold climate applications
- Excellent serviceability
- Rubber lined for increased wear life

COMPONENTS

Chassis

- Self regulating cyclone tank complete with built in float system
- Built in anti-turbulence feed sections
- Optional split for two products
- Heavy duty steel construction
- Easy access to all serviceable areas
- Optional overflow weirs to aid removal of silt

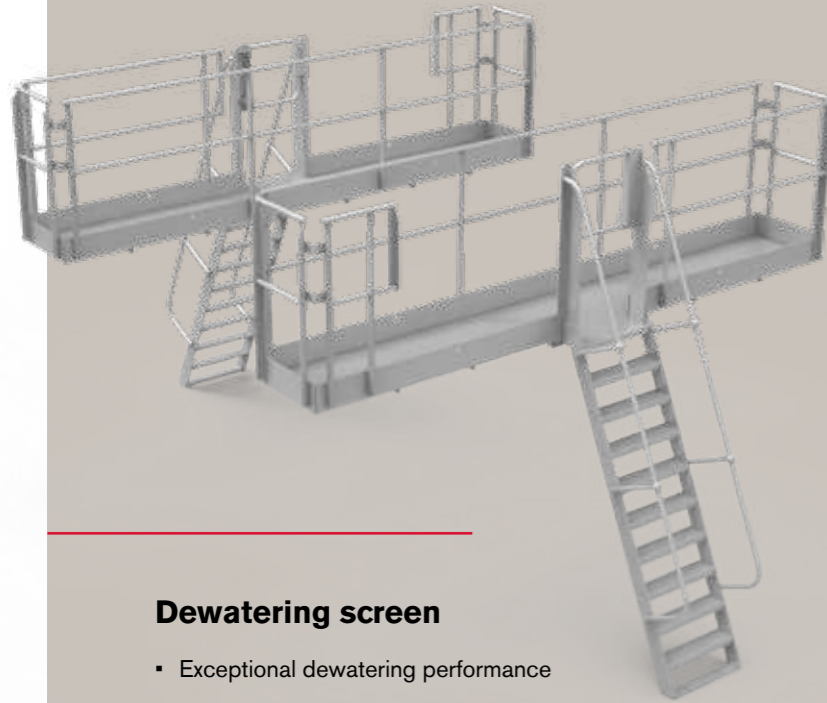
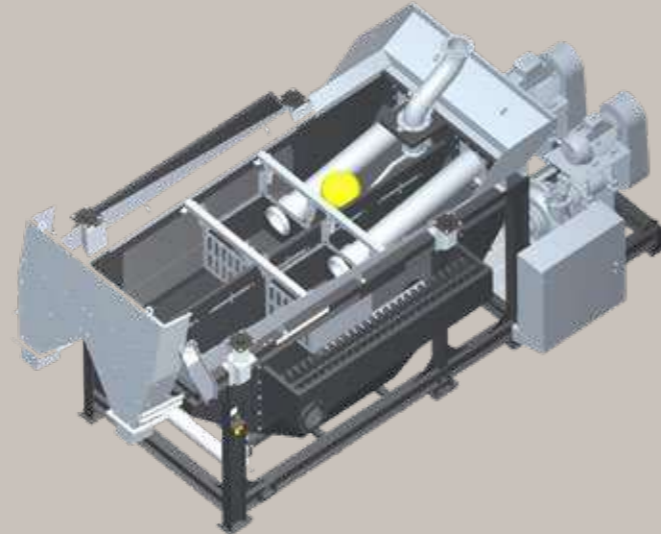

Access

- Fully galvanised, reversible walkways
- Optional expanded metal or G.R.P. flooring
- Access to all serviceable areas

Dewatering screen

- Exceptional dewatering performance
- From 6x2 to 14x6
- 2 x vibratory motors
- Polyurethane modules and side protection
- Polyurethane low friction chute liners
- Marshmallow screen mounts for smoother running

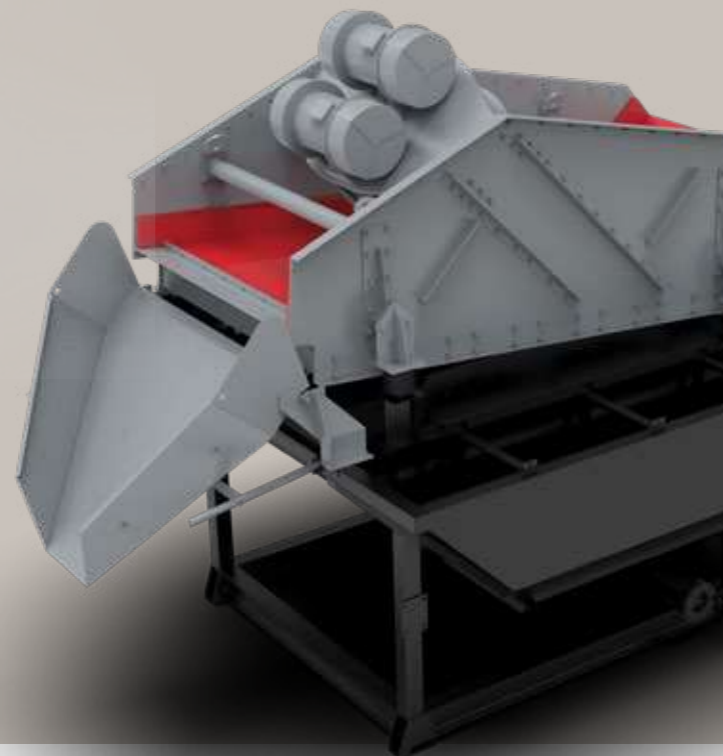

TRANSPORT

The FM Compact™ range are designed to fit standard shipping containers in the most cost effective way:

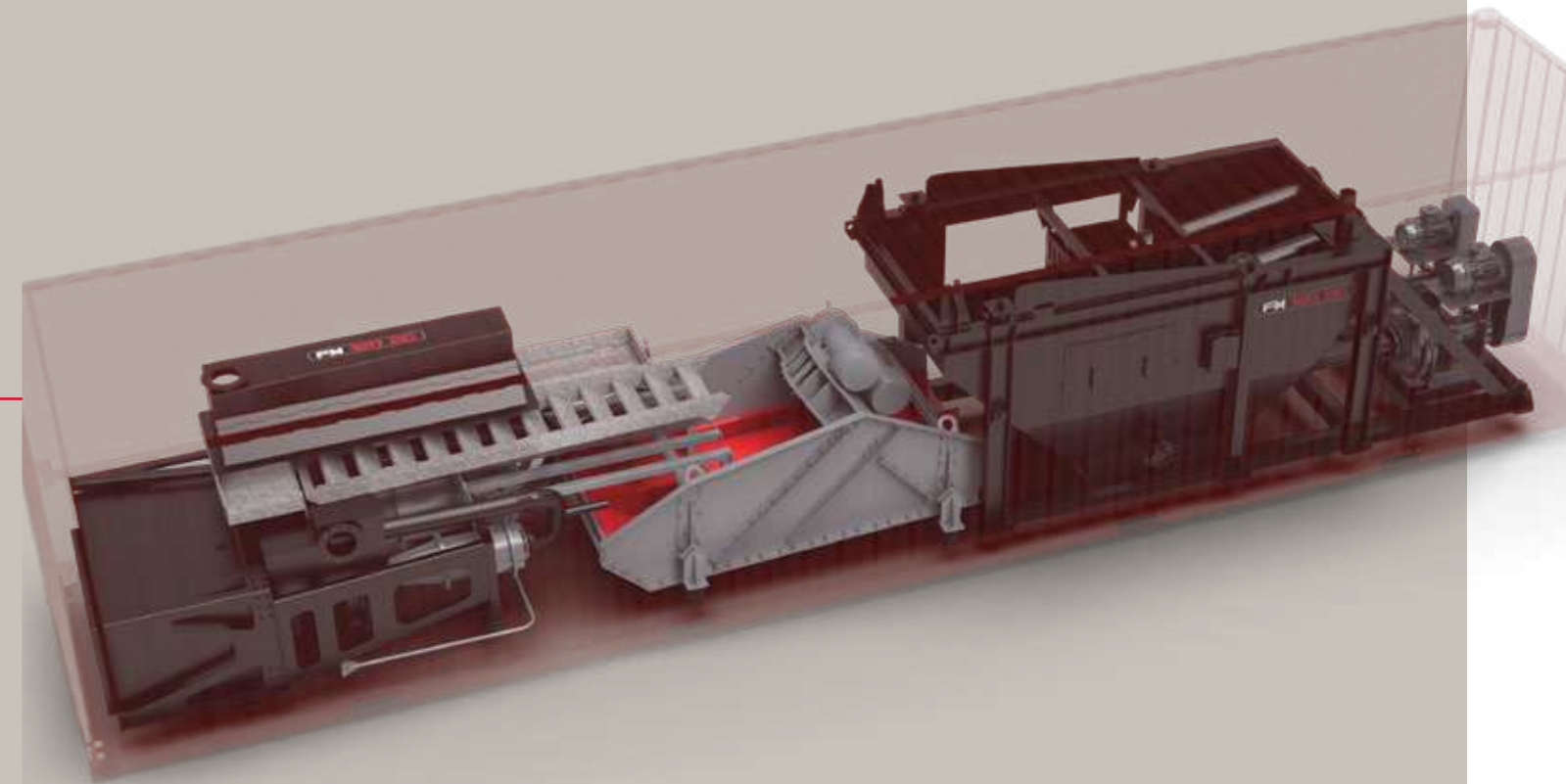

Machine Model	Container requirement
FM 20c	1 x 40'
FM 60c	1 x 40'
FM 120c	1 x 40'
FM 120c 2G	1 x 20' and 1 x 40'
FM 150c	1 x 40'
FM 150c 2G	1 x 20' and 1 x 40'
FM 200c	2 x 40'
FM 200c 2G	2 x 40' (High Cube)

TECHNICAL SPECIFICATION

The FM Compact™ range comes in 8 models ranging from 20 to 200tph and capable of producing 2 grades of in-spec sand.

- FM 20c
- FM 60c
- FM 120c
- FM 120c - 2 Grade
- FM 150c
- FM 150c - 2 Grade
- FM 200c
- FM 200c - 2 Grade



Model Pictured: FM 120c - 2G

Machine Model	FM 20c	FM 60c	FM 120c	FM 120c 2G	FM 150c	FM 150c 2G	FM 200c	FM 200c 2G
Max Tonnage (tph)	20	60	120	120	150	150	200	200
Dewatering Screen (m [ft])	1.8x0.6 [6x2]	2.4x1.2 [8x4]	3.7x1.5 [12x5]	3.7x1.5 [12x5]	3.7x1.5 [12x5]	3.7x1.5 [12x5]	4.3x1.8 [14x6]	4.3x1.8 [14x6]
Hydrocyclone	G4 - 375mm	G4 - 500mm	G4 - 660mm	G4 - 500mm	2 x G4 - 500mm	2 x G4 - 500mm	2 x G4 - 660mm	G4 - 660mm
Pump Size (mm)	100/100	150/125	200/150	150/125 & 200/150	250/200	2 x 200/150	250/200	2 x 200/150
Pump Power (kW [hp])	11 [15]	18.5 [25]	30 [40]	15 [20] & 22 [30]	37 [50]	2 x 22 [30]	45 [60]	22 [30] & 30 [40]
Inlet Flange (mm [Inch])	200 [8]	250 [10]	250 [10]	250 [10]	250 [10]	250 [10]	250 [10]	300 [12]
Outlet Flange (mm [Inch])	200 [8]	200 [8]	250 [10]	250 [10]	250 [10]	250 [10]	300 [12]	250 [10]
Total Power (kW [hp])	13 [17.5]	23 [31]	38 [51]	45 [60.5]	45 [60]	52 [70]	57.4 [77]	64.4 [86]

Technical Specs for FM Models.

DIMENSIONS

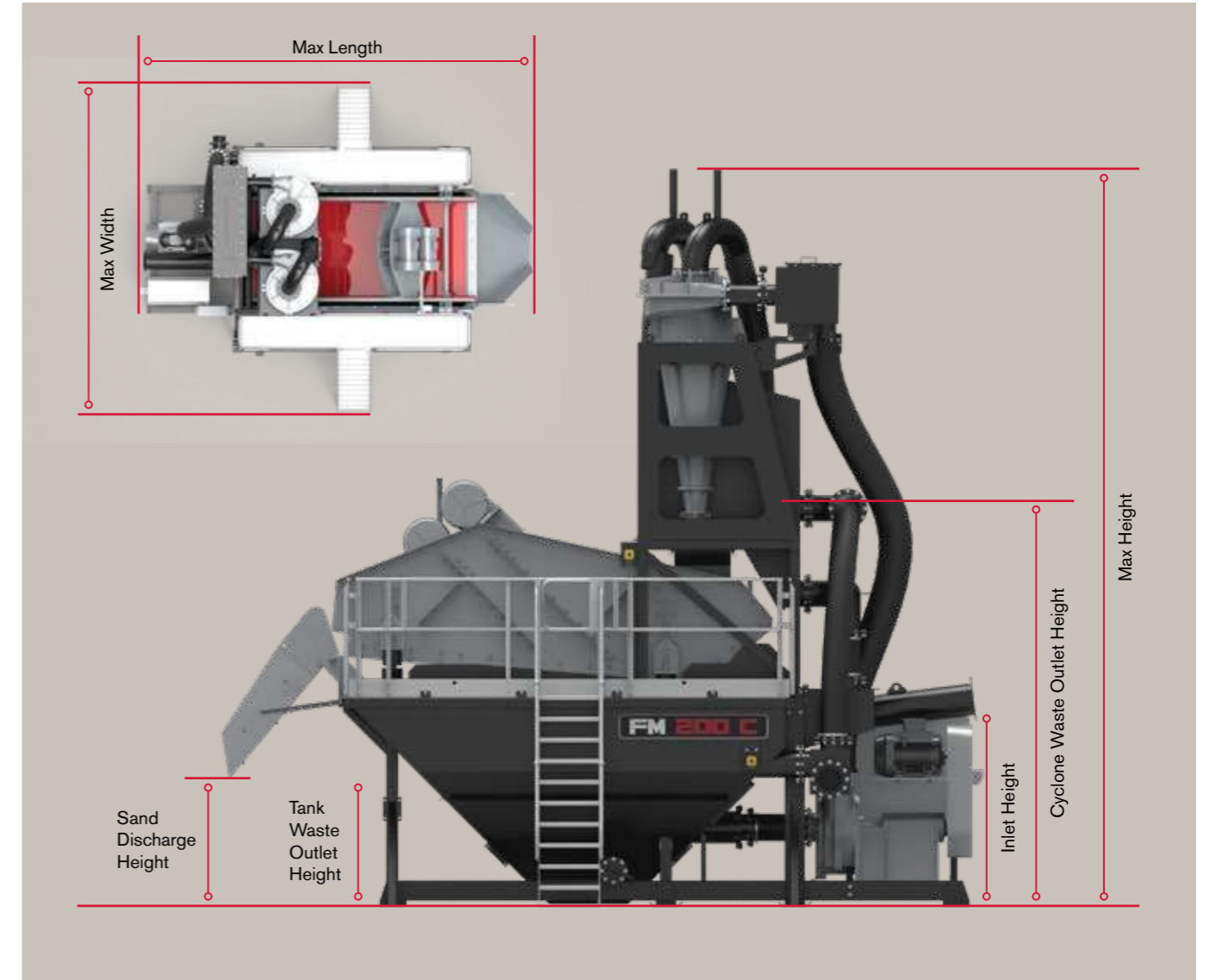

Machine Model	FM 20c	FM 60c	FM 120c	FM 120c 2G	FM 150c	FM 150c 2G	FM 200c	FM 200c 2G
Max Height	4310 (14'2")	6080 (19'11")	7070 (23'3")	6740 (22'12")	7300 (23'9")	7300 (23'9")	7430 (23'5")	8200 (26'10")
Max Length	4450 (14'8")	6840 (22'6")	6540 (21'6")	7580 (24'10")	6900 (22'6")	6900 (22'6")	7680 (25'3")	6900 (22'7")
Max Width	3230 (10'8")	2740 (9'0")	3590 (11'10")	4450 (23'5")	4310 (14'2")	4310 (14'2")	6440 (21'2")	4800 (15'9")
Inlet Height	1300 (4'4")	1690 (5'7")	1920 (6'4")	1950 (6'5")	1920 (6'4")	1920 (6'4")	2090 (6'11")	1800 (5'10")
Tank Waste Outlet Height	880 (2'11")	1490 (4'11")	970 (3'3")	1680 (5'6")	1490 (4'11")	1490 (4'11")	1280 (4'2")	1800 (5'10")
Discharge Height	1350 (4'5")	1262 (4'2")	1670 (5'6")	1900 (6'3")	1670 (5'6")	1670 (5'6")	1300 (4'3")	1800 (5'10")

Dimensions Full FM Compact™ range. Units: Metric-mm [Imperial].



WASHING SYSTEMS

WASHING AS IT SHOULD BE



CHECK OUT TEREX WASHING SYSTEMS
VIDEOS ON YOUTUBE:

www.youtube.com/terexwashingsystems



TEREX WASHING SYSTEMS

FARLOUGH SITE

32 Farlough Road,
Dungannon,
Co. Tyrone,
Northern Ireland, BT71 4DT

Tel: +44(0) 28 8771 8500
Email: TWS.sales@terex.com

www.terex.com/washing

Effective Date: October 2020 Product specifications and prices are subject to change without notice or obligation. The photographs and/or drawings in this document are for illustrative purposes only. Refer to the appropriate Operator's Manual for instructions on the proper use of this equipment. Failure to follow the appropriate Operator's Manual when using our equipment or to otherwise act irresponsibly may result in serious injury or death. The only warranty applicable to our equipment is the standard written warranty applicable to the particular product and sale and Terex makes no other warranty, express or implied. Products and services listed may be trademarks, service marks, or trade names of Terex Corporation and/or its subsidiaries in the USA and other countries. All rights are reserved. Terex is a registered trademark of Terex Corporation in the USA and many other countries. © 2020 Terex Corporation.